



**Seth Jai Parkash Mukand Lal Institute of Engineering &  
Technology**

**Department of Mechanical Engineering**

**Student Handbook**

**Semester-VII<sup>th</sup>**

**July-December, 2020**

# **Department of Mechanical Engineering**

## **Vision**

To excel by adapting to rapidly changing technical diversity of Mechanical Engineering, producing highly competent engineers to meet the challenges of industry and society through creativity and innovation.

## **Mission**

1. To nurture professionally competent mechanical engineers by providing comprehensive knowledge of principles of engineering in the relevant field.
2. Developing analytical and research abilities with a multi-disciplinary approach, encouraging culture of continuous learning through adoption of new technologies to solve complex problems.
3. To create professionals committed to professional ethics with good leadership, team spirit and communication skills, and high moral responsibilities towards society.

## **Program Educational Objectives (PEO's)**

- To prepare the students with good understanding of the subjects of Mechanical engineering with design, analytical and problem solving skills.
- To prepare the students to use subject knowledge along with modern IT tools to formulate, solve and analyse engineering problems giving due consideration to their impact on socioeconomic, health, culture and environment.
- To inculcate in students the sense of ethics, professionalism, creativity, independent thinking, self-confidence and good communication skills through personality development programs and extra-curricular activities.

## **Program Specific Objectives (PSO's)**

- Provide ability to formulate, analyse and evaluate mechanical systems or processes by implementing learned principle of Mechanical engineering.
- To prepare professionals with ability to adapt to a rapidly changing scenario through learning and applications of new skills and technologies.

## **Programme Objectives (PO's)**

After completion of the course, B.Tech. Mechanical Engineering graduates will have ability:

- To apply the laws of science, mathematics, engineering & Mechanical engineering to solve engineering problems.
- To identify, formulate and analyse the complex engineering problems by the application of principles of science, mathematics and engineering.
- To design a computing system and processes to meet the specified needs of problem solution.
- To use research methods to analyse, generate and interpret the data obtained from computing system developed, to find valid solutions of the problems.
- Ability to select and utilize modern IT tools, techniques for modelling and analysis of complex engineering activities.
- Will be able to assess socioeconomic, health, safety and cultural issues in context to obtained engineering knowledge, and relevant engineering responsibilities.
- Will understand the need of sustainable development by realizing the impact of engineering practices in context to societal and environmental issues.
- Work as professional mechanical engineers with commitment towards social, ethical & professional responsibilities.
- Work in multidisciplinary areas with efficient functioning, management and leadership qualities as an individual, team member or leader.
- Ability of effective communication with engineering professionals as well as society through oral and written modes.
- Apply tools and techniques of project management to plan, manage and complete the projects.
- Recognize the need of technological changes and adapting the change as lifelong learning process.

Bachelor of Technology (Mechanical Engineering) Kurukshetra University, Kurukshetra

*SCHEME OF STUDIES/EXAMINATIONS(w.e.f. 2015-16 onwards)*

**Semester – VII**

S. No.	Course No.	Course Title	Teaching Schedule				Allotment of Marks				Duration of Exam (Hrs.)
			L	T	P	Hours/ Week	Theory	Sessional	Practical	Total	
1	ME-401N	<a href="#">Measurement and Control</a>	4	0	0	4	75	25	0	100	3
2	ME-403N	<a href="#">Mechatronics</a>	4	0	0	4	75	25	0	100	3
3	HS-401N	Entrepreneurship	3	0	0	3	75	25	0	100	3
4		<a href="#">DEC – I*</a>	4	0	0	4	75	25	0	100	3
5		<a href="#">DEC –II*</a>	3	0	0	3	75	25	0	100	3
6	ME-405N	<a href="#">Measurement and Control Lab</a>	0	0	2	2	0	40	60	100	3
7	ME-407N	<a href="#">Mechatronics Lab</a>	0	0	2	2	0	40	60	100	3
8	ME-409N	<a href="#">Project-I**</a>	0	0	8	8	0	100	100	200	3
9	ME-411N	<a href="#">Industrial Training</a> (Viva-Voce)***	2	0	0	2	0	40	60	100	3
10	ME-413N	<a href="#">Seminar-I</a>	0	2	0	2		100	0	100	
		<b>Total</b>	<b>20</b>	<b>02</b>	<b>12</b>	<b>34</b>	<b>375</b>	<b>445</b>	<b>280</b>	<b>1100</b>	

\* The students should select two Departmental Elective Courses (DEC) from the following list.

Course No.	DEC-I	Course No.	DEC-II
ME-415N	<a href="#">Non-Conventional Machining</a>	ME-427N	<a href="#">Finite Element Methods in Engineering</a>
ME-417N	<a href="#">Soft Computing Techniques</a>	ME-429N	<a href="#">Advanced Manufacturing Technology</a>
ME-419N	<a href="#">Non-Destructive Evaluation &amp; Testing</a>	ME-431N	<a href="#">Robotics: Mechanics and Control</a>
ME-421N	<a href="#">Design and Optimization</a>	ME-433N	<a href="#">Simulation of Mechanical Systems</a>
ME-423N	<a href="#">Computational Fluid Dynamics</a>	ME-435N	<a href="#">Control Engineering</a>
ME-425N	<a href="#">Fundamentals of Gas Dynamics</a>	ME-437N	<a href="#">Environmental Pollution and Abatement</a>

\*\*The project should be initiated by the students in the beginning of VII<sup>th</sup> semester and will be evaluated at the end of the semester on the basis of a presentation and report.

\*\*\*The performance of the student will be evaluated after the presentation delivered and the report submitted by the student related to Industrial training undertaken after VI<sup>th</sup> semester.

## **B. Tech. 7<sup>th</sup> Semester Mechanical Engineering**

Course No.	Course Title	Teaching Schedule			Allotment of Marks			Duration of Exam (Hrs.)
		L	T	P	Theory	Sessional	Total	
ME-401N	MEASUREMENT AND CONTROL	4	0	0	75	25	100	3
CO1	Ability to identify and select proper measuring instrument for specific application.							
CO2	Knowledge of working principle of measuring instruments.							
CO3	Knowledge of errors and uncertainty in relation to measuring instruments.							
CO4	Identify sensors for measurement of vibration, thermo-physical properties and radiation properties of surfaces.							
CO5	Knowledge of different control systems, characteristics and application.							
CO6	Mathematically model and analyze system/process for standard input responses.							

### **UNIT-I**

**Fundamentals of Measurements:** Definition, application of measurement instrumentation, functional elements of a generalized measuring system, measuring standards, types of measurement, types of input to measuring instruments and instrument system, classification of measuring instruments, merits and demerits of mechanical measuring systems, comparison of mechanical measuring system with electrical measuring systems, calibration.

**Generalized Measurement System:** Introduction, types of error, types of uncertainties, propagation of uncertainties in compound quantity, Static performance parameters: accuracy, precision, resolution, static sensitivity, linearity, hysteresis, dead band, backlash, and drift, sources of error, selection of measuring instruments, mechanical and electrical loading.

### **UNIT-II**

**Motion, Force and Torque Measurement:** Introduction, relative motion, measuring devices, electromechanical, optical, photo electric, Moore-Fringe, pneumatic, absolute motion devices, seismic devices, spring mass & force balance type, calibration, hydraulic load cell, pneumatic load cell, elastic force devices, separation of force components, electro mechanical methods, torque transducer, torque meter.

**Measurement of Strain and Vibrations:** Type of strain gauges and their working, strain gauge circuits, Mcleod gauge, Pirani gauge, temperature compensation, strain rosettes, analysis of strains.

**Vibration and noise measurement:** Seismic instruments, vibration pick-ups and decibel meters.

### **UNIT-III**

**Pressure and Flow Measurement:** Moderate pressure measurement, monometers, elastic transducer, dynamic effects of connecting tubing, high pressure transducer, low pressure measurement, calibration and testing, quantity meters, positive displacement meters, flow rate meters, variable head Meters, variable area meters, rotameters, pitot-static tube meter, drag force flow meter, turbine flow meter, electronic flow meter, electro-magnetic flow meter, hot-wire anemometer.

**Temperature Measurement:** Introduction, measurement of temperature, non-electrical methods – solid rod thermometer, bimetallic thermometer, liquid in- glass thermometer, pressure thermometer, electrical methods – electrical resistance thermometers, semiconductor resistance sensors (thermistors), thermo-electric sensors, thermocouple materials, radiation methods (pyrometry), total radiation pyrometer, selective radiation pyrometer

#### UNIT-IV

**Control Analysis:** Introduction, classification of control systems, control system terminology, servomechanism, process control and regulators, manual and automatic control systems, physical systems and mathematical models, linear control systems, Laplace transform, transfer function, block diagram, signal flow graphs.

#### Reference and Text Books:

1. Mechanical measurements & control- By D.S. Kumar, Metropolitan book
2. Instrumentation and Mechanical measurements- By A.K. Tayal, Galgotia Publ.
3. Measurements systems application and design-By Ernest Doebelin, McGraw-Hill
4. Automatic Control Systems- By S. Hasan Saeed

**NOTE: In the semester examination, the examiner will set 8 questions in all, at least one question from each unit, and students will be required to attempt only 5 questions.**

#### LECTURE PLAN

Month	Class	Topic/Chapter Covered	Academic Activity	Test/Assignment
July	7thSemester	Introduction to measurement and control	Teaching	
July	7thSemester	Introduction to measurement and control	Teaching	
July	7thSemester	measuring standards	Teaching	
July	7thSemester	types of measurement	Teaching	Assignment
July	7thSemester	types of input to measuring instruments and instrument system	Teaching	
July	7thSemester	classification of measuring instruments,	Teaching	

July	7thSemester	comparision of mechanical measuring system with electrical measuring systems	Teaching	Assignment
July	7thSemester	calibration.	Teaching	Assignment
Aug.	7thSemester	Introduction, types of error, types of uncertainties,	Teaching	Assignment
Aug.	7thSemester		Teaching	
Aug.	7thSemester	propagation of uncertainties in compound quantity, Static performance parameters: accuracy, precision, resolution, static sensitivity, linearity, hysteresis, dead band, backlash, and drift, sources of error, selection of measuring instruments, mechanical and electrical loading.	Teaching	
Aug.	7thSemester		Teaching	
Aug.	7thSemester		Teaching	
Aug.	7thSemester		Teaching	
Aug.	7thSemester	Motion, Force and Torque Measurement: Introduction	Teaching	
Aug.	7thSemester	relative motion, measuring devices, electromechanical, optical, photo electric, Moore-Fringe,	Teaching	Assignment
Aug.	7thSemester		Teaching	
Aug.	7thSemester	pneumatic, absolute motion devices, seismic devices	Teaching	
Aug.	7thSemester	spring mass & force balance type, calibration, hydraulic load cell, pneumatic load cell, elastic force devices	Teaching	Assignment
Aug.	7thSemester	separation of force components, electro mechanical methods, torque transducer, torque meter.	Teaching	
Aug.	7thSemester	Measurement of Strain and Vibrations: Type of strain gauges	Teaching	
Sept.	7thSemester	Classification of unconventional machining processes	Teaching	Assignment

Sept.	7thSemester	their working, strain gauge circuits, Mcleod gauge,	Teaching	
Sept.	7thSemester	Pirani gauge, temperature compensation, strain rosettes	Teaching	
Sept.	7thSemester	analysis of strains.	Teaching	Assignment
Sept.	7thSemester	Vibration and noise measurement: Seismic instruments	Teaching	
Sept.	7thSemester	vibration pick-ups and decibel meters.	Teaching	
Sept.	7thSemester	Pressure and Flow Measurement: Moderate pressure measurement	Teaching	Assignment
Sept.	7thSemester	monometers, elastic transducer,	Teaching	
Sept.	7thSemester	dynamic effects of connecting tubing, high pressure transducer	Teaching	
Sept.	7thSemester	Introduction, effects of vibration	Teaching	
Sept.	7thSemester	on machine tools	Teaching	Assignment
Sept.	7thSemester	low pressure measurement, calibration and testing, quantity meters, positive displacement meters	Teaching	
Oct.	7thSemester	flow rate meters, variable head	Teaching	
Oct.	7thSemester	Meters, variable area meters, rotameters, pitot-static tube meter	Teaching	
Oct.	7thSemester	drag force flow meter, turbine	Teaching	
Oct.	7thSemester	flow meter, electronic flow meter, electro-magnetic flow meter.	Teaching	Assignment
Oct.	7thSemester	hot-wire anemometer.	Teaching	
Oct.	7thSemester	Temperature Measurement: Introduction, measurement of temperature, non-electrical methods – solid rod thermometer	Teaching	
Oct.	7thSemester	bimetallic thermometer, liquid in-	Teaching	Assignment
Oct.	7thSemester	glass thermometer, pressure thermometer, electrical methods – electrical resistance thermometers	Teaching	

Oct.	7thSemester	semiconductor resistance sensors (thermistors), thermo-electric	Teaching	
Nov.	7thSemester	sensors, thermocouple materials,	Teaching	
Nov.	7thSemester	radiation methods (pyrometry), total radiation pyrometer, selective radiation pyrometer	Teaching	
Nov.	7thSemester	Introduction, classification of control systems, control system terminology, servomechanism, process control	Teaching	Assignment
Nov.	7thSemester	physical systems and mathematical models, linear control systems, Laplace transform	Teaching	

## TUTORIAL SHEET – 1

1. What are primary, secondary & working standards? write in detail.
2. what are fundamental dimensions & supplementary unit. Explain briefly?
3. compare mechanical vs electrical measuring systems with step input?
4. What are the requirements for dynamics measurements. explain its static characteristics?.  
what are the various types of standard instruments used for this purpose?
5. What are the requirements for dynamics measurements? explain dynamic performance of first order mechanical systems with step input?
6. What are different types of error in measuring systems?
7. What are sources of these errors in measuring systems?
8. Define:
  - a) Accuracy
  - b) precision
  - c) Resolution
9. Differentiate between mechanical and electrical loading?
10. Explain selection criteria for measuring instruments?

## TUTORIAL SHEET – 2

1. What do you understand by the term:
  - (i)Speed of response and (ii)Measuring lag (iii)Fidelity & dynamic error
2. What is single and multisample measurement data ? Explain statistical attributes and various methods of presentation ?
3. What are the various types of experimental error found ? Explain briefly their primary causes.
4. What is in accuracy and what are its sources ?
5. Explain paratalex, controllable and uncontrollable effects of inaccuracy.
6. What do you understand by the term 'uncertainty' ? What are the various methods for detecting precision uncertainty ?
7. What is Chauvenet's criteria for rejecting a dubious reading ? Explain its static characteristics. What are the various types of standard instrument used for this purpose ?
8. What are the requirements for dynamic measurement ? Explain dynamic performance of first order mechanical systems with step input.
9. Differentiate between speed of response and Measuring lag?
10. Differentiate between fidelity and speed of response?

## TUTORIAL SHEET – 3

1. What do you understand by the term "Transducer" ? Explain its primary functions.
2. How Transducers are classified ? Explain briefly.
3. What are Electrostatic transducers ? Explain its principles, theory of various types, advantages and limitations.

4. What are fixed contact mechano-resistive transducers which are the basic requirement for them and how they are classified ?
5. What are bimetallic thermometers explain in detail?
6. What are liquid in glass thermometers, explain in detail?
7. What are semiconductor resistance sensors, explain?
8. What is selective radiation pyrometer, explain?
9. Explain hot wire anemometer?
10. Explain electromagnetic flow meter

#### **TUTORIAL SHEET-4**

1. What are different materials of construction of a strain ? Compare bonded and unbonded strain gauges?
2. How strain gauges are mounted ? explain
3. Explain the effects of temp. on a strain gauges and how these effects are compensated?
4. Explain Mathematical analysis of ballast & D.C., wheat stone bridge circuit?
5. How thrust load and forces are calculated with resistance strain gauges? What are elastic load cells and proving rings? Explain
6. Explain fluid pressure measurement in pipe and container using strain gauges?
7. What are the various methods employed for measuring torque in transmission of shaft under axial and bending loads in varying ambient conditions?
8. Explain control system by an example. classify control system?
9. Explain laplace transform and transfer function by examples?
10. Explain servo mechanism, process control and regulators manual and automatic control systems

Roll No:.....

Total Pages: 03

**BT-7/D-19 31166**  
**Measurement & Control**  
**ME-401N (Group i) Opt.1**

Time: Three Hours

Max. Marks:75

**Note :** Attempt five questions in all, selecting at least one question from each Unit. Unless stated otherwise, the symbols have their usual meaning in context with the subject. All questions carry equal marks.

**Unit I**

1. Differentiate between Primary, Secondary and Tertiary types of measurements. Also, cite suitable examples for each of the case. 15
2. What are the different sources of errors in measurements and measuring instruments? Also, explain (a) Hysteresis, (b) Accuracy, (c) Repeatability and (d) Drift. 15

**Unit II**

- 3 Describe the method of measuring torque of rotating shafts using strain gauges. Also, explain how elastic sensing elements can be used for measurement of force. 15
4. Derive an expression for Gauge Factor of Strain Gauge when change in resistivity due to strain is almost negligible. Also describe the construction of foil type strain gauges. 15

**Unit III**

5. An electromagnetic flow meter is used to measure the average flow rate of a liquid flowing through a pipe of diameter 50 mm. The velocity profile is symmetrical and can be assumed uniform. The flux density in the liquid has a peak value of  $0.1 \text{ Wb/m}^2$ . The output from the flow meter electrodes is taken to an amplifier of gain 1000 and impedance between the electrodes is 250 kilo-ohms. The input impedance of the meter is 2.5 mega-ohms. Determine the average velocity of the liquid when peak to peak voltage at the amplifier output is 0.2 V. 15
6. A thermometer with a time constant of 50 seconds has been used for measuring temperature cycling with 500 s time period. Calculate the amplitude attenuation (ratio of output to input), the phase angle and the corresponding time lag. 15

**Unit IV**

7. Define open and closed loop control system with the help of example. Also state their advantages and disadvantages. 15

8. Draw the signal flow graph and determine  $C/R$  for the block diagram shown below. 15

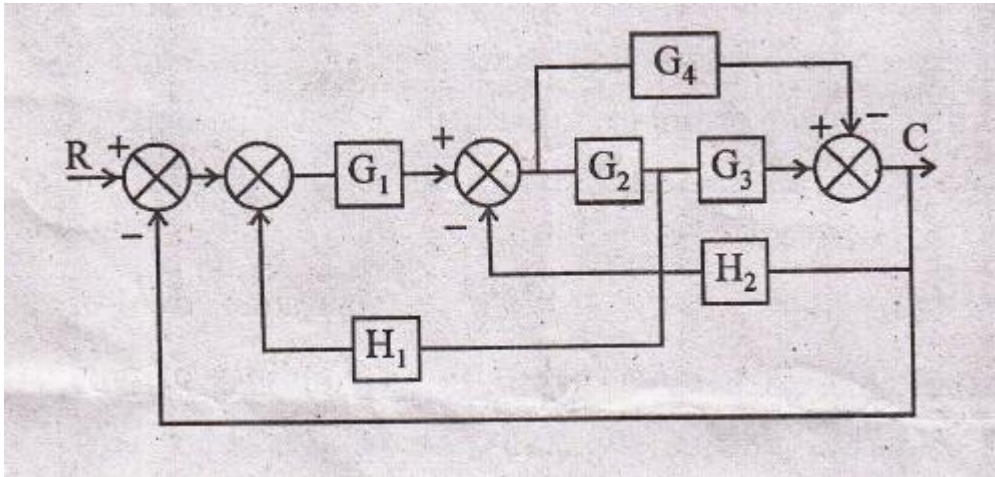

Rollno-----

Total pages:03

**BT-7/D-18**  
**Measurement and control**  
**ME-403E**

Time:3hours]

[Max Marks:75

Note: There are eight questions in this paper.All questions carry 15 marks each.Attempt five questions in all,selecting at least one question from each section

**Section-A**

1.Differentiate the following

- (1) Dead band and hysteresis
- (2)Sensitivity and linearity
- (3)Backlash and drift
- (4)Accuracy and precision
- (5)Mechanical and electrical loading 15.

2. (a)Describe in brief various functional elements of generalized measurement system?7.5  
(b)Write a technical note on chavlets criteria?7.5

**Section-B**

3. (a) Write a short note on pneumatic and hydraulic load cell? 7.5  
(b) Write a short note on vibration pick ups and decibel meters? 7.5

- 4(a)How variable flow meters differ from variable area meters? 7.5  
(b)Discuss in detaildrag force and turbine flow meters? 7.5

**SectionC**

- 5(a) With neat sketch explain in detail Moore Fringe? 7.5  
(b)Define Gauge factor of a strain gauge? Define pirani Gauge? 7.5

- 6 (a) Explain in detail high pressure and low pressure measurement? 7.5  
(b) Write a technical note on pyrometer.Also explain total radiation and selection radiation pyrometers? 7.5

**Section D**

- 7(a) What is servo mechanism? Discuss in detail the process, control and regulators with regards to control systems? 7.5  
(b)Define with the help of examples manual and automatic control systems 7.5

8 (a) State regard to control system

(1) Forward path (2) Summing point

(2) Take off point (4) loop

(5) Transfer function(6)Stability

6

(b) Write the various rules of block diagram reduction technique for predicting transfer function

## B. Tech. 7<sup>th</sup> Semester Mechanical Engineering

Course No.	Course Title	Teaching Schedule			Allotment of Marks			Duration of Exam (Hrs.)
		L	T	P	Theory	Sessional	Total	
ME-403N	MECHATRONICS	4	0	0	75	25	100	3
CO 1	To understand Mechatronics system and study of number system and Boolean algebra and able to convert number systems from one system to another.							
CO 2	Students will be able to understand different sensors and transducers as well as recognize various Pneumatic and Hydraulic system components along with their symbols.							
CO 3	Able to explain mechanical actuation systems and architecture of microprocessors.							
CO 4	Able to understand basic structure of PLC and its applications and concepts of Robotics.							

### UNIT - I

**Introduction to Mechatronics and its Systems:** Evolution, Scope, Measurement Systems, Control Systems, open and close loop systems, sequential controllers and microprocessor based controllers, mechatronics approach.

**Basics of Digital Technology:** Number System, Boolean algebra, Logic Functions, Karnaugh Maps, Timing Diagrams, Flip-Flops, Applications.

### UNIT - II

**Sensors and transducers:** Introduction, performance terminology-Displacement, Position and Proximity, Velocity and motion, force, Fluid Pressure-Temperature Sensors-Light Sensors-Selection of Sensors-Signal Processing.

**Pneumatic and Hydraulic actuation systems:** actuation systems, Pneumatic and hydraulic systems, directional control valves, pressure control valves, cylinders, process control valves, rotary actuators.

### UNIT - III

**Mechanical actuation systems:** Mechanical systems, types of motion, kinematics chains, cams, gear trains, ratchet and pawl, belt and chain drives, bearings, mechanical aspects of motor selection.

**Microprocessor:** Introduction, Architecture, Pin Configuration, Instruction set, Programming of Microprocessors using 8085 instructions-Interfacing input and output devices-Interfacing D/A converters and A/D converters, Applications, Temperature control, Stepper motor control, Traffic light controller.

#### **UNIT - IV**

**Programmable Logic Controller:** Introduction, Basic structure, Input/output Processing, Programming, Mnemonics, Timers, Internal relays and counters, Data handling, Analog Input/Output, Selection of a PLC.

**Robotics:** Introduction, types of robots, Robotic control, Robot drive systems Robot end effectors, selection parameters of a robot, applications.

#### **Text Books:**

1. R. K Rajput, "A Textbook of Mechatronics", Edition 2010.

#### **Reference Books:**

1. Bolton W., "Mechatronics", Longman, Second Edition, 2004.
2. Hystad Michael B. and Alciatore David G., "Introduction to Mechatronics and Measurement Systems", McGraw Hill International Editions, 2003.
3. HMT Ltd., "Mechatronics", Tata McGraw Hill Publishing Co. Ltd., 1998.
4. Nitaigour Premchand Mahalik, "Mechatronics Principles, Concepts and Applications", Tata McGraw-Hill publishing company Ltd, 2003.

**NOTE: In the semester examination, the examiner will set 8 questions in all, at least one question from each unit, and students will be required to attempt only 5 questions.**

### Lecture Plan Mechatronics (ME-403N)

<b>Month</b>	<b>Class</b>	<b>Topic/Chapter Covered</b>	<b>Academic Activity</b>	<b>Test/Assignment</b>
July	7 <sup>th</sup> Semester	Evolution, Scope, Introduction to Mechatronics & Measurement Systems	Teaching	
July	7 <sup>th</sup> Semester	Control Systems, Classification of Control system, Automatic control systems, Open and close loop systems	Teaching	
July	7 <sup>th</sup> Semester	Sequential controllers and microprocessor based controllers, Industrial controllers	Teaching	
July	7 <sup>th</sup> Semester	Mechatronics approach	Teaching	
Aug	7 <sup>th</sup> Semester	Introduction to Digital electronics, Number System	Teaching	
Aug	7 <sup>th</sup> Semester	Boolean algebra, Boolean laws	Teaching	
Aug	7 <sup>th</sup> Semester	Logic Functions, Logic Gates	Teaching	
Aug	7 <sup>th</sup> Semester	Karnaugh Maps, Timing Diagrams	Teaching	
Aug	7 <sup>th</sup> Semester	Flip-Flops, Applications	Teaching	Assignment
Aug	7 <sup>th</sup> Semester	Introduction, Performance Terminology- Displacement, Position and Proximity, Velocity and motion, Force	Teaching	
Aug	7 <sup>th</sup> Semester	Fluid Pressure-Temperature Sensors- Light Sensors-Selection of Sensors	Teaching	

Aug	7 <sup>th</sup> Semester	Signal Processing	Teaching	
Aug	7 <sup>th</sup> Semester	Actuation systems, Pneumatic system	Teaching	
Aug	7 <sup>th</sup> Semester	Hydraulic systems	Teaching	
Sep	7 <sup>th</sup> Semester	Directional control valves, Pressure control valves, Cylinders, Process control valves	Teaching	
Sep	7 <sup>th</sup> Semester	Rotary actuators	Teaching	Assignment
Sep	7 <sup>th</sup> Semester	Mechanical systems, Types of motion, Kinematics chains, Cams, Gear trains, Ratchet and pawl,	Teaching	
Sep	7 <sup>th</sup> Semester	Belt and chain drives, Bearings, Mechanical aspects of motor selection	Teaching	
Sep	7 <sup>th</sup> Semester	Introduction, Architecture	Teaching	
Sep	7 <sup>th</sup> Semester	Pin Configuration, Instruction set	Teaching	
Sep	7 <sup>th</sup> Semester	Programming of Microprocessors using 8085 Instructions	Teaching	
Sep	7 <sup>th</sup> Semester	Interfacing input and output devices- Interfacing D/A converters and A/D converters	Teaching	
Sep	7 <sup>th</sup> Semester	Applications, Temperature control	Teaching	
Sep	7 <sup>th</sup> Semester	Stepper motor control, Traffic light controller	Teaching	

Oct	7 <sup>th</sup> Semester	Programmable Logic Controller: Introduction, Basic structure, Input/output Processing	Teaching	Assignment
Oct	7 <sup>th</sup> Semester	Programming of PLC		
Oct	7 <sup>th</sup> Semester	Mnemonics, Timers, Internal relays and counters	Teaching	
Oct	7 <sup>th</sup> Semester	Data handling, Analog Input/Output	Teaching	
Oct	7 <sup>th</sup> Semester	Selection of a PLC	Teaching	
Oct	7 <sup>th</sup> Semester	Introduction, Types of robots	Teaching	
Oct	7 <sup>th</sup> Semester	Robotic control, Robot drive systems	Teaching	
Oct	7 <sup>th</sup> Semester	Robot end effectors	Teaching	
Oct	7 <sup>th</sup> Semester	Selection parameters of a robot, Applications	Teaching	Assignment

## **Tutorial Sheet-I**

1. What is Mechatronics? Give an example of a typical mechatronic system, highlighting the primary technologies within such systems.
2. What are the components of a mechatronics system? Give a brief outline of how information flows through a Mechatronic System.
3. What is a control system? Enumerate and define the elements of a control system? List examples of control system.
4. Discuss classification of control system. Compare open loop and closed loop systems with examples.
5. Discuss number systems. Discuss Decimal Number System and Binary Number System.
6. Explain laws of Boolean algebra.
7. What is a flip-flop? Explain the principle of operation of S-R flip-flop with truth table.
8. Explain Binary addition, subtraction and multiplication with examples.
9. Define logic functions.
10. Write short note on timing diagrams.

## **Tutorial Sheet-II**

1. What is transducer? What are the functions of a transducer? How are transducers classified?
2. Describe briefly the following:
  - (i) Thermistors and resistance thermometers
  - (ii) Wire resistance strain gauges
3. Explain briefly with neat sketches, the following:
  - (i) Wire-wound strain gauges
  - (ii) Foil type strain gauges
  - (iii) Semiconductor strain gauges
  - (iv) Capacitive strain gauges

4. How does a digital transducer differ from an analog transducer?
5. Explain briefly the following pressure transducers:
  - (i) Resistance type pressure transducers
  - (ii) Pressure voltage type
  - (iii) Piezoelectric type
6. Name various pneumatic actuation systems and Hydraulic actuation systems What operational characteristics would be expected from a pneumatic actuator, particularly in terms of:  
Operational velocity, actuation force, resolution, compliance, actuator responsiveness
7. Explain briefly the following:
  - (i) Pneumatic check valve
  - (ii) Double acting cylinder
  - (iii) Three position cylinder
8. Write in detail about displacement, position and proximity sensors.
9. Write a note on light sensors.
10. Explain some of the factors that are considered for selection of sensors.

### **Tutorial Sheet-III**

1. What is an actuator? List the various types of actuators. Briefly outline the operating ranges of electrical, hydraulic and pneumatic actuators, in terms of operating torques and speeds.
2. Define the following terms: Machine; Kinematic link; Kinematic pair, Kinematic chain, Inversion of mechanism.
3. What is a bearing? How are bearings classified?
4. Explain types of belts and chain in brief.
5. What are servo motors? Explain briefly. Give some aspects of motor selection.
6. Define microprocessor. What are the uses of microprocessors? What are the different parts of microprocessor systems?
7. Explain briefly Intel 8085 microprocessor with the help of a block diagram. Discuss difference between microcontroller & microprocessor.

8. What is a microcontroller? How are microcontrollers classified? Describe briefly 8051 microcontroller.
9. Give an overview of instruction set of a microprocessor.
10. Explain programming of microprocessors using 8085 instructions.

#### **Tutorial Sheet-IV**

1. What are programmable logic controllers (PLCs)? State the special features. Explain briefly with a neat diagram, the architecture of a PLC.
2. Explain briefly the programming of a PLC. Explain Mnemonics and Master & jump controls.
3. State the factors for selecting a PLC and uses of PLC. What are the advantages of PLC?
4. Discuss timer and counters in brief.
5. Define the term Robotics. What are the basic components of a robotic system? State the main function of each of the components.
6. How are robots classified? Explain briefly the configuration of robots:
  - (i) Cartesian coordinate configuration
  - (ii) Cylindrical configuration
  - (iii) Spherical configuration
7. Explain briefly the various tests which are performed on robots to judge their suitability. What do you understand by forward and reverse kinematics?
8. Explain briefly the following:
  - (i) Robot sensing and vision
  - (ii) Robot programming languages
  - (iii) Load carrying capacity of robot
9. Write short note on end effectors.
10. Discuss some selection parameters of a robot.

**B TECH/D-18 (7<sup>th</sup> Semester)**  
**MECHATRONICS, ME-403N**

*Time allowed: 3 hours*

*Maximum marks: 75*

**UNIT-1**

- 1) What is meant by real time mechatronics system?
  - (a) Describe the application of mechatronics system in real world.
  - (b) Describe the CNC, FMS and CIM as mechatronics application.
- 2) What is Boolean and Boolean number? Explain the methods of obtaining the Boolean expressions from the truth table.

**UNIT-2**

- 3) Explain the transducers with the Doppler Effect and tachogenerator.
- 4) What is the essential difference in construction between a poppet valve and spool valve? State the reason why poppet valve design is mainly confined to small air valves.

**UNIT-3**

- 5) Sketch and explain the various kinds of cams.
- 6) What is architecture of a microprocessor? Explain the procedure of how external devices can be connected to a microprocessor.

**UNIT-4**

- 7) What are the advantages of PLC over a relay control system? Draw the symbol and state the equivalent PLC instruction for each of the following:
  - (a) NO CONTACT
  - (b) NC CONTACT
  - (c) Relay Output
  - (d) Timer
  - (e) Counter
- 8) Define and industrial robot. What are the basic elements of a robot? Explain them briefly. Also give the classification of a robot.

**BT-7/D-19**  
**MECHATRONICS**  
**Option II**  
**ME-403N**

Time: Three Hours

Maximum Marks: 75

**Note:** Attempt Five questions in all, selecting at least one question from each unit. ALL questions carry equal marks.

**Unit I**

1. (a) Briefly explain the design of mechatronics systems.  
(b) What is Control system? What are its requirements? Also explain the basic elements of a feedback system?
2. What are Boolean algebra and Boolean numbers? Explain the different types of number representation systems with suitable example.

**Unit II**

3. (a) State, in general the principal of operation of transducers and highlight their difference with sensors. Distinguish between accuracy and sensitivity of a transducer  
(b) Discuss how velocity is measured by using electromagnetic transducers.
4. What are the three types of pressure control valves? Explain the working of these valves.

**Unit III**

5. What are the factors to be considered when selecting the belt drives? With a neat diagram explain the “timing belt” used in transmission system with its advantages.
6. Explain the procedure of how external devices can be connected to a microprocessor. Design hardware to interface 7 segment LEDs with 8085 microprocessor.

**Unit IV**

7. Compare the PLC and a general-purpose computer. Draw the ladder rungs to represent the following:  
(a) two switches that are NO and either of the switches have to be closed for a lamp to operate; (b) both NO switches have to be closed for a coil to be energized in order for a solenoid to operate (c) a control valve is switched ON by pressing a spring return pushbutton start switch and it remains actuated until another spring return pushbutton stop is pressed (d) a motor is to come ON if there is no input from thermostat switch; (e) stop a motor from running when a pushbutton is pressed. The input field device is a closed pushbutton.

8. What are the uses of robots in modern industries? What are its essential components?  
Explain the selection parameters of a robot.

<b><u>B. Tech. 7<sup>th</sup> Semester Mechanical Engineering</u></b>								
Course No.	Course Title	Teaching Schedule			Allotment of Marks			Duration of Exam (Hrs.)
		L	T	P	Theory	Sessional	Total	
<b>HS-401N</b>	<b>ENTREPRENEURESHIP</b>	3	0	0	75	25	100	3
CO1	Ability to recognize distinct entrepreneurial traits							
CO2	Ability to assess parameters of opportunities and constraints for new business ideas.							
CO3	Student will be able to attain leadership and managerial skill.							
CO4	Ability to understand and prepare a feasibility project report and to communicate them effectively both orally and in writing.							
CO5	Knowledge of current theories, models, techniques and tools used in areas of finance, Information Technologies, Marketing.							
CO6	Knowledge of the ethical environment impacting business organizations.							

#### UNIT –I

**Entrepreneurship** : Concept and Definitions; Entrepreneurship and Economic Development; Types of Entrepreneurs; Factor Affecting Entrepreneurial Growth – Economic, Non-Economic Factors; EDP Programmes; Entrepreneurial Training; Traits/Qualities of an Entrepreneurs; Manager Vs. Entrepreneur, types of entrepreneurships, Entrepreneurial myths.

#### UNIT-II

**Opportunity Identification and Product Selection:** Entrepreneurial Opportunity Search & Identification; Criteria to Select a Product; Conducting Feasibility Studies; Sources of business ideas, launching a new product; export marketing, Methods of Project Appraisal, Project Report Preparation; Project Planning and Scheduling. Sources of finance for entrepreneurs.

#### UNIT –III

**Small Enterprises and Enterprise Launching Formalities** : Definition of Small Scale; Rationale; Objective; Scope; SSI; Registration; NOC from Pollution Board; Machinery and Equipment Selection , Role of SSI in Economic Development of India; major problem faced by SSI, MSMEs – Definition and Significance in Indian Economy; MSME Schemes, Challenges and Difficulties in availing MSME Schemes.

#### UNIT -IV

**Role of Support Institutions and Management of Small Business** : Director of Industries; DIC; SIDO; SIDBI; Small Industries Development Corporation (SIDC); SISI; NSIC; NISBUD; State Financial Corporation SIC; Venture Capital : Concept, venture capital financing schemes offered by various financial institutions in India, Legal issues – Forming business entity, considerations and criteria, requirements for formation of a Private/Public Limited Company,

**Note:**

- Exercises / activities should be conducted on ‘generating business ideas’ and identifying problems and opportunities.
- Interactive sessions with Entrepreneurs, authorities of financial institutions, Government officials should be organized.

**Suggested Readings:**

1. “Entrepreneurship development small business enterprises”, Pearson, Poornima M Charantimath, 2013.
2. Roy Rajiv, “Entrepreneurship”, Oxford University Press, 2011.
3. “Innovation and Entrepreneurship”, Harper business- Drucker.F, Peter, 2006.
4. “Entrepreneurship”, Tata Mc-graw Hill Publishing Co.ltd new Delhi- Robert D. Hisrich, Mathew J. Manimala, Michael P Peters and Dean A. Shepherd, 8th Edition, 2012
5. Entrepreneurship Development- S.Chand&Co.,Delhi- S.S.Khanka 1999
6. Small-Scale Industries and Entrepreneurship. Himalaya Publishing House, Delhi – Vasant Desai 2003.
7. Entrepreneurship Management -Cynthia, Kaulgud, Aruna, Vikas Publishing House, Delhi, 2003.
8. Entrepreneurship Ideas in Action- L. Greene, Thomson Asia Pvt. Ltd., Singapore, 2004.

**Note: Question Paper will consist of four units. Eight questions will be set in the question paper by selecting two from each unit. The students will be required to attempt five questions, selecting at least one from each unit.**

**LECTURE PLAN**  
**ENTREPRENEURSHIP**  
**HS – 401 N**

<b>Month</b>	<b>Class</b>	<b>Topic/ Chapter covered</b>	<b>Academic activity</b>	<b>Test/ assignment</b>
July	7 <sup>th</sup> Sem.	Introduction to Entrepreneurship.	Teaching	
July	7 <sup>th</sup> Sem.	Concept and Definitions; Entrepreneurship	Teaching	
July	7 <sup>th</sup> Sem.	Introduction to Economic Development	Teaching	
July	7 <sup>th</sup> Sem.	Concept and Definitions; Economic Development;	Teaching	
July	7 <sup>th</sup> Sem.	Types of Entrepreneurs	Teaching	
July	7 <sup>th</sup> Sem.	Factor Affecting Entrepreneurial Growth – Economic, Non-Economic factor	Teaching	
July	7 <sup>th</sup> Sem.	EDP Programmes;	Teaching	
July	7 <sup>th</sup> Sem.	Entrepreneurial Training	Teaching	
August	7 <sup>th</sup> Sem.	Traits/Qualities of an Entrepreneurs; Manager Vs. Entrepreneur	Teaching	Assignment
August	7 <sup>th</sup> Sem.	Types of entrepreneurships	Teaching	
August	7 <sup>th</sup> Sem.	Entrepreneurial myths	Teaching	
August	7 <sup>th</sup> Sem.	Entrepreneurial Opportunity Search & Identification	Teaching	
August	7 <sup>th</sup> Sem.	Criteria to Select a Product; Conducting Feasibility Studies	Teaching	
August	7 <sup>th</sup> Sem.	Sources of business ideas	Teaching	
August	7 <sup>th</sup> Sem.	Launching a new product	Teaching	
August	7 <sup>th</sup> Sem.	Export marketing	Teaching	
August	7 <sup>th</sup> Sem.	Methods of Project Appraisal	Teaching	
August	7 <sup>th</sup> Sem.	Project Report Preparation	Teaching	
August	7 <sup>th</sup> Sem.	Project Planning and Scheduling	Teaching	
August	7 <sup>th</sup> Sem.	Sources of finance for entrepreneurs	Teaching	
August	7 <sup>th</sup> Sem.	Definition of Small Scale	Teaching	
Sept.	7 <sup>th</sup> Sem.	Rationale; Objective, Scope	Teaching	
Sept.	7 <sup>th</sup> Sem.	SSI; Registration; NOC from Pollution Board	Teaching	
Sept.	7 <sup>th</sup> Sem.	Machinery and Equipment Selection	Teaching	
Sept.	7 <sup>th</sup> Sem.	Role of SSI in Economic Development of India	Teaching	Test
Sept.	7 <sup>th</sup> Sem.	Major problem faced by SSI	Teaching	Assignment
Sept.	7 <sup>th</sup> Sem.	MSMEs Definition	Teaching	

Sept.	7 <sup>th</sup> Sem.	Definition and Significance in Indian Economy	Teaching	
Sept.	7 <sup>th</sup> Sem.	MSME Schemes	Teaching	
Sept.	7 <sup>th</sup> Sem.	Challenges and Difficulties in availing MSME Schemes.	Teaching	
Sept.	7 <sup>th</sup> Sem.	Director of Industries; DIC; SIDO;SIDBI	Teaching	
Sept.	7 <sup>th</sup> Sem.	Small Industries Development Corporation (SIDC); SISI; NSIC; NISBUD	Teaching	
Sept.	7 <sup>th</sup> Sem.	State Financial Corporation SIC; Venture Capital : Concept, venture capital financing schemes offered by various financial institutions in India	Teaching	
Oct.	7 <sup>th</sup> Sem.	Venture Capital : Concept	Teaching	
Oct.	7 <sup>th</sup> Sem.	Venture capital financing schemes offered by various financial institutions in India	Teaching	Assignment
Oct.	7 <sup>th</sup> Sem.	Legal issues – Forming business entity	Teaching	
Oct.	7 <sup>th</sup> Sem.	Considerations and criteria, requirements for formation of a Private/Public Limited Company	Teaching	
Oct.	7 <sup>th</sup> Sem.	Extra Classes for revision	Teaching	
Oct.	7 <sup>th</sup> Sem.	Extra Classes for revision	Teaching	
Oct.	7 <sup>th</sup> Sem.	Extra Classes for revision	Teaching	
Oct.	7 <sup>th</sup> Sem.	Extra Classes for revision	Teaching	Test
Nov.	7 <sup>th</sup> Sem.	Extra Classes for revision	Teaching	
Nov.	7 <sup>th</sup> Sem.	Extra Classes for revision	Teaching	
Nov.	7 <sup>th</sup> Sem.	Extra Classes for revision	Teaching	
Nov.	7 <sup>th</sup> Sem.	Extra Classes for revision	Teaching	Test
Nov.	7 <sup>th</sup> Sem.	Extra Classes for revision	Teaching	
Nov.	7 <sup>th</sup> Sem.	Extra Classes for revision	Teaching	Test
Nov.	7 <sup>th</sup> Sem.	Extra Classes for revision	Teaching	
Nov.	7 <sup>th</sup> Sem.	Extra Classes for revision	Teaching	
Nov.	7 <sup>th</sup> Sem.	Extra Classes for revision	Teaching	
Nov.	7 <sup>th</sup> Sem.	Extra Classes for revision	Teaching	

## **Tutorial Sheet -1**

1. Explain the steps in launching own venture.
2. Describe the procedure for registration of small scale industries.
3. Explain the steps in preparation of techno economic feasibility report of a manufacturing small enterprise.
4. What is the modern concept of marketing? State function of marketing.
5. Describe some financial support programs of banks for small scale industries.
6. Describe the types and salient characteristic of successful Entrepreneurs.

## **Tutorial Sheet -2**

1. Describe the functions performed by Entrepreneurs and role in economic growth of country.
2. What factors do influence the emergence and development of Entrepreneurship?
3. Distinguish between an Entrepreneur and a Manager.
4. What do you mean by EDP. Discuss the course contents and curriculum of an EDP.
5. Discuss the various phases and evaluations involved in an EDP.
6. What are the various sources of finance available to a small scale enterprise to raise funds .

## **Tutorial Sheet -3**

1. Describe the Challenges and Difficulties in availing MSME Schemes.
2. What do you mean by Opportunity. Justify the need and significance of Opportunity identification & Selection.
3. Discuss the methods of project appraisal used to appraise a proposed proposal.
4. Write a short note on following
5. SSI.

6. MSME.
7. NOC from pollution board.
8. Machinery & equipment selection.

## **ENTREPRENEURSHIP**

**Paper: HS- 303-N**

### **UNIT- I**

1. Define Entrepreneur. "Entrepreneurship is the cause for which economy is effect. "Discuss This

In light of imitative taken by Govt. to promote entrepreneurship in India. (15)

2. Define the following:

- (a) Entrepreneur and Manager
- (b) Entrepreneurial Competencies.
- (c) Creativity as an essence of entrepreneurship. (3x5=15)

### **UNIT- II**

3. Discuss the following:

- (a) Financial Feasibility of project
- (b) Idea to opportunity mapping
- (c) Opportunity identification (3x5=15)

4. Define feasibility analysis. Discuss the importance of technical and operational feasibility

in feasibility analysis. (15)

### **UNIT-III**

5. Define SSI. Also discuss the rationale of setting up and promoting small enterprises in emerging

economy India. (15)

6. Discuss the following:

- (a) Key area in which technology can be used for improving the operational efficiency in the business.
- (b) Content of Project report
- (c) Critical path method (3x5=15)

### **UNIT-IV**

7. Discuss the various types of financial and non-financial support offered by Govt. to promote

entrepreneurship in India. (15)

8. The success or failure of a business plan depends a lot on clarity about the market and marketing

plan. Explain the implication of this statement in start-up ventures. (15)

## **ENTREPRENEURSHIP**

**Paper: ME- 402-E**

### **UNIT- I**

- 1(a) Why should engineers study economics? 5
- (b) What do you mean by overheads, prime factory and cost? 10
- (c) Write briefly on various causes of depreciation. 5
2. (a) Explain 'Diminishing Balance Method' for calculating Depreciation. 10
- (b) Discuss the concept goods of consumer goods and producer. (0)

### **UNIT- II**

3. Write briefly; why entrepreneurship is very important for Indian economy? Also describe different 'Entrepreneurial Characteristics'. (20)
4. (a) Write briefly on nature of replacement problems and replacement of items which deteriorate. 10
- b) How is selection made for investment and replacement alternatives. 10

### **UNIT-III**

5. Discuss briefly the role and scope of small scale and ancillary industries. Also discuss the role of NABARD for entrepreneurship development in India. 20
6. (a) Write briefly on the role of various controlling agencies which accord clearance before starting a venture? 15
- (b) Elements of Concurrent engineering. 5

### **UNIT-IV**

7. Write briefly on
  - (a) Tools for techno-economic feasibility of entrepreneurial project. (10)
  - (b) Market Survey and Marketing Research for entrepreneur. (10)
8. Write briefly on:
  - (a) Alternate sources of finance for entrepreneurs. (10)
  - (b) Financial support programme of banks. (10)

**B. Tech. 7<sup>th</sup> Semester Mechanical Engineering**

Course No.	Course Title	Teaching Schedule			Allotment of Marks			Duration of Exam (Hrs.)
		L	T	P	Theory	Sessional	Total	
ME-415N	NON-CONVENTIONAL MACHINING	4	0	0	75	25	100	3
CO1	Knowledge of the principle of working of NCM process							
CO2	Knowledge of the need for NCM processes and impact on society.							
CO3	Knowledge of the working principle and mechanism of metal removal in the various unconventional machining process.							
CO4	Ability to identify the process parameters of NCM processes and their effect on different processes.							
CO5	Knowledge of application of various non-conventional manufacturing process.							
CO6	Ability to select a suitable modern machining process for given applications.							

**UNIT I**

**Introduction:** Introduction, need of Non-conventional machining processes, Rapid prototyping processes, their classification, consideration in process selection.

**Ultrasonic Machining:** Element of process, design of cutting tool, metal removal mechanism, effect of parameters, economic consideration, limitation and applications, surface finish.

**UNIT II**

**Electrochemical Machining:** Element of process, process chemistry, metal removal mechanism, tool design, accuracy, surface finish and work material characteristics, economic consideration, advantage, limitation and application, Electrochemical grinding, debarring and honing, chemical machining.

**EDM:** Principal and metal removal mechanism, generators, electrode feed control, electrode material, tool electrode tool design, EDM wire cutting, surface finish, accuracy and application.

**UNIT III**

**Jet Machining:** Principal and metal removal mechanism of abrasive and water jet machining, process variables, design of nozzle, advantage, limitation and application.

Plasma arc machining, Electron beam machining, Laser beam machining, their principal of metal removal mechanism, process parameter, advantage and limitations.

**UNIT IV**

**Rapid Prototyping:** Fundamentals, process chain, physics of processes, principal and process mechanism of SLA, SGA, LOM, FDM, and SLS processes, their advantage and limitations, application of RP process, RP data format, STL file format, STL file problems, STL file repair, others translators and formats.

**Rapid Tooling Process:** Introduction, fundamentals, classifications, indirect RT processes, principal of Silicon Rubber Molding, Epoxy Tooling, Spray Metal Tooling, Pattern for

investment casting, Vacuum casting and vacuum forming processes, direct RT processes, Shape Deposition manufacturing, their advantage, limitations and applications.

**Reference and Text Books:**

1. Modern machining processes – By P.C. Pandey and M.S. Shan.
2. Machining Science – By Gosh and Malik, Affiliated East west
3. Nontraditional Manufacturing Processes – By G.F. Benedict, Maicel Dekker.
4. Advanced Method Of Machining – By J.A. Mcgeongh, Chapman And Hall.
5. Electrochemical Machining Of Metals – By Ruryantsev&Davydov, Mir Pub.
6. Rapid Prototyping: Principal And Application by CK Chua, World Scientific Publishing.

**NOTE: In the semester examination, the examiner will set 8 questions in all, at least one question from each unit, and students will be required to attempt only 5 questions.**

**LECTURE PLAN**

**NON-CONVENTIONAL MACHINING  
ME-415N**

Month	Class	Topic/Chapter Covered	Academic Activity	Test/Assignment
July	7 <sup>TH</sup> Semester	<b>Introduction:</b> Introduction, need of Non-conventional machining processes.	Teaching	
July	7 <sup>TH</sup> Semester	Rapid prototyping processes	Teaching	
July	7 <sup>TH</sup> Semester	Rapid prototyping classification, consideration in process selection	Teaching	Assignment
August	7 <sup>TH</sup> Semester	<b>Ultrasonic Machining:</b> Element of process.	Teaching	
August	7 <sup>TH</sup> Semester	Design of cutting tool, metal removal mechanism	Teaching	
August	7 <sup>TH</sup> Semester	Effect of parameters, economic consideration, limitation and applications, surface finish	Teaching	Assignment
August	7 <sup>TH</sup> Semester	<b>Electrochemical Machining:</b> Element of process, process chemistry, metal removal mechanism,	Teaching	
August	7 <sup>TH</sup> Semester	Tool design, accuracy, surface finish	Teaching	Assignment

August	7 <sup>TH</sup> Semester	Work material characteristics, economic consideration, advantage, limitation and application		
August	7 <sup>TH</sup> Semester	Electrochemical grinding, debarring and honing, chemical machining.	Teaching	
August	7 <sup>TH</sup> Semester	Principal and metal removal mechanism, generators	Teaching	
August	7 <sup>TH</sup> Semester	ode feed control, electrode material, tool	Teaching	Assignment
August	7 <sup>TH</sup> Semester	ode tool design,	Teaching	
August	7 <sup>TH</sup> Semester	EDM wire cutting, surface finish, accuracy and application	Teaching	
August	7 <sup>TH</sup> Semester	<b>Jet Machining:</b> Principal and metal removal mechanism of abrasive jet machining	Teaching	
Sept.	7 <sup>TH</sup> Semester	Water jet machining, process variables, design of nozzle, advantage, limitation and application.	Teaching	
Sept.	7 <sup>TH</sup> Semester	Plasma arc machining, their principal of metal removal mechanism	Teaching	Assignment
Sept.	7 <sup>TH</sup> Semester	Electron beam machining, their principal of metal removal mechanism	Teaching	
Sept.	7 <sup>TH</sup> Semester	Laser beam machining, their principal of metal removal mechanism	Teaching	
Sept.	7 <sup>TH</sup> Semester	Process parameter, advantage and limitations	Teaching	
Sept.	7 <sup>TH</sup> Semester	<b>Jet Machining:</b> Principal and metal removal mechanism of abrasive and water jet machining	Teaching	
Sept.	7 <sup>TH</sup> Semester	Process variables, design of nozzle,	Teaching	

Sept.	7 <sup>TH</sup> Semester	Advantage, limitation and application. Plasma arc machining, Electron beam machining	Teaching	Assignment
Sept.	7 <sup>TH</sup> Semester	Laser beam machining, their principal of metal removal mechanism	Teaching	
Sept.	7 <sup>TH</sup> Semester	s parameter, advantage and limitations	Teaching	
Oct.	7 <sup>TH</sup> Semester	<b>Prototyping: Fundamentals, process chain, physics of processes</b>	Teaching	
Oct.	7 <sup>TH</sup> Semester	Principal and process mechanism of SLA, SGA, LOM, FDM	Teaching	
Oct.	7 <sup>TH</sup> Semester		Teaching	
Oct.	7 <sup>TH</sup> Semester		Teaching	Assignment
Oct.	7 <sup>TH</sup> Semester	Principal and process mechanism of SLS processes, their advantage and limitations, application of RP process	Teaching	
Oct.	7 <sup>TH</sup> Semester	RP data format, STL file format, STL file problems	Teaching	
Oct.	7 <sup>TH</sup> Semester	STL file repair, others translators and formats	Teaching	Assignment
Oct.	7 <sup>TH</sup> Semester	<b>Rapid Tooling Process:</b> Introduction, fundamentals, classifications	Teaching	Assignment
Oct.	7 <sup>TH</sup> Semester	Indirect RT processes, principal of Silicon Rubber Molding, Epoxy Tooling, Spray Metal Tooling.	Teaching	
Nov.	7 <sup>TH</sup> Semester	Pattern for investment casting, Vacuum casting	Teaching	
Nov.	7 <sup>TH</sup> Semester	Vacuum forming processes, direct RT processes, Shape Deposition manufacturing, their advantage, limitations and applications	Teaching	
Nov.	7 <sup>TH</sup> Semester		Teaching	Assignment

### **TUTORIAL-1**

1. What is the difference between conventional and non-conventional machining processes?
2. What are the essential physical process parameters for an efficient use of modern machining process?
3. Why NCM processes are selected for manufacturing?
4. Explain the following parameters with respect to USM:
  - i) Effect of amplitude and frequency of vibration.
  - ii) Effect of grain diameter.
5. List and explain the variables used in AJM.
6. List the application of water Jet machining.

### **TUTORIAL-2**

1. Explain with neat schematic diagram of electro chemical grinding and their advantages and application
2. Explain the following process: (a) Vacuum casting (b) vacuum forming
3. Explain with sketch progressive stages of metal removal in chemical blanking.
4. List the application of chemical machining.
5. Explain briefly EDM process characteristics
6. What are the application of PAM and also mention advantages and limitations?

### **TUTORIAL-3**

1. How NCM machining processes are classified?
2. Explain with neat diagram construction and working of USM processes
3. Draw schematic diagram of Abrasive Jet Machining (AJM). Explain its construction and working
4. Draw schematic sketch of electro chemical machining and explain briefly the elements of ECM process.
5. What are factors on which the selection of a resist for all in chemical machining depends?
6. Explain the following parameters with respect to USM:
  - (a) Effect of applied static load.
  - (b) Effect of slurry

#### **TUTORIAL-4**

1. Draw neat sketch of a typical set up for Laser Beam Machining (LBM) and explain briefly.
2. What are the advantages and limitations of LBM?
3. Draw neat diagram of EDM (Electrical Discharge Machining). Explain its construction and working
4. Explain the construction and working principle of Plasma Arc Machining (PAM) with neat sketch and List the general guideline for designing the torch.
5. With neat sketch, explain working principle of Electron Beam Machining (EBM).
6. What is Rapid Prototyping? Explain principal and process mechanism of SLA.

Roll No.....

Total Pages: 02

**BT-7/D-19**  
**NON CONVENTIONAL MACHINING**  
**ME-415N**

**Time:** Three hours.  
75.

**Maximum marks:**

**Note:** Attempt Five questions in all, selecting one question form each Unit.

**Unit I**

1. Make a list of various non-conventional machining processes and provide three typical applications of each of these processes. (15)
2. Discuss the influence of the following parameters of USM process:
  - (a) Amplitude and frequency of vibration
  - (b) Grain size
  - (c) Abrasive concentration. (15)

**Unit II**

3. Explain the effect of high temperature and pressure on the electrolyte used in ECM Process. Illustrate the Electrochemical Honing and Electrochemical Grinding processes in brief with neat sketches. (15)
4. With the help of neat sketch, explain wire cut electrical discharge machining. Explain the tool feed mechanism used in EDM Process. (15)
5. List few materials which cannot be machined effectively by water jet machining. How do you compare water jet machining process with conventional machining process considering quality, surface finish, material removal rate as criteria?
6. (a) Describe the thermal features of melting and evaporation process in LBM. (7)  
(b) Describe the effects of temperature and election pressure on the quality of machining in EBM. (8)
7. (a) After 3D geometric modelling, a user can either make a part through NC programming or through rapid prototyping. What are the basic differences between NC programming and RP in terms of the CAD model? (5)  
(b) STL files are problematic. Is this a fair statement to make? Discuss. (5)  
(c) Which step in the entire process chain is, in your opinion the shortest, most tedious and most automated? Support your choice. (5)

8. (a) Explain with neat sketch the principle, process parameters and process details of stereolithography. (8)

(b) What is FDM process? List the application areas of fusion deposition modelling. (7)

Roll No.....

Total Pages: 02

**BT-7/D-18**

**NON CONVENTIONAL MACHINING**

**ME-415N**

Time: Three hours.

Maximum marks: 75.

Note: Attempt five questions in all, selecting at least one question from each unit. Q. No. 1 is compulsory.

1. Explain the reasons that lead to the development of unconventional machining process. 15
2. (a) Explain with sketch, different tool feeding mechanisms in ultrasonic machining. 7  
(b) Explain different parameters which affect ultrasonic machining. 8
3. (a) Explain different elements of electrochemical machining process. 8  
(b) Explain with sketch the electrochemical grinding operation. 7
4. (a) List the commonly used dielectric fluid used in EDM process. What properties should they possess? 7  
(b) Explain the mechanism of EDM showing the circuit and movement of ions 8
5. (a) How does the following parameters affect the MRR in abrasive jet machining? 9
  - i. Nozzle gap distance
  - ii. Abrasive size
  - iii. Nozzle pressure  
(b) What are the process variables that affect the performance of water-jet machining process? 6
6. (a) Explain with a neat sketch the non-thermal generation of plasma and mechanism of metal removal. 8  
(b) With a neat diagram, Explain the generation and control of an electron beam 7
7. (a) What is rapid prototyping and explain about different steps involved in rapid prototyping technology.  
(b) What are the advantages and limitation of FDM Process? 8
8. Describe the working principle and advantages and disadvantage of SLA Process with neat diagram. 15

## B. Tech. 7<sup>th</sup> Semester Mechanical Engineering

Course No.	Course Title	Teaching Schedule			Allotment of Marks			Duration of Exam (Hrs.)
		L	T	P	Theory	Sessional	Total	
ME – 429N	ADVANCED MANUFACTURING TECHNOLOGY	3	0	0	75	25	100	3
CO 1	Able to understand different types of composite material characteristics,							
CO 2	Knowledge of different surface coating and treatment processes.							
CO 3	Knowledge of plastics, moulding, casting and machining of plastics.							
CO 4	Knowledge of thread manufacturing, their inspection and measurement.							
CO5	Knowledge of metal forming, rolling, die casting and design of dies.							
CO6	Ability of cost estimation and preparation of report with representation skills.							

### UNIT I

**Hot machining**, Machining of Plastics, Unit heads, Plastics cooling, electro forming, Surface Cleaning and Surface Treatments, Surface Coatings, Paint Coating and Slushing, Adhesive Bonds, Adhesive Bond Joints, Adhesives, Surface Coating for Tooling, Graphite Mould Coating, **Vacuum Mould Process**. Introduction, Types of Composites materials, Agglomerated Materials, Reinforced materials, Laminates, Surface Coated Materials, Production of Composite Structures, Fabrication of particulate composite Structures, Fabrication of reinforced Composite, Fabrication of Laminates, Machining, Cutting and Joining of Composites.

### UNIT II

**Polymers:** Introduction, Polymerization, Addition of Polymers, Plastics, Types of plastics, Properties of Plastics, Processing of Thermoplastic Plastics, Injection Moulding, Casting of Plastics, Machining of plastics, other processing methods of plastics Introduction, casting, thread chasing, Thread Rolling, Die Threading and Tapping, Thread Milling, Thread Measurement and Inspection.

### UNIT III

**Metal Forming:** Theoretical basis of metal forming, classification of metal forming processes, cold forming, hot working, Warm working, Effect of variables on metal forming processes,

Methods of analysis of manufacturing processes, Open Die forging, Rolling Power Rolling, Drawing, Extrusion.

#### **UNIT IV**

**Die Casting:** Introduction, Product Application, Limitation of Die Casting, Die Casting Machines, Molten metal Injection systems, hot chamber machines, Cold chamber machines, Die casting Design, Design of Die casting Dies, Types of Die casting Dies, Die design, Die material, Die Manufacture, Die Lubrication and Coating, Preheating of Dies, Vacuum Die Casting, Recent trends In Die Casting Process. Definition, Cost accounting or costing, Elements of costing, cost structures, Estimation of cost elements, Methods of estimating, Data requirements of cost estimating, Steps in making cost estimate, Chief factors in cost estimating, Numerical examples, calculation of machining times, Estimation of total unit time

#### **Reference and Text Books:**

1. Principles of Manufacturing- By J.S.Campbell, Tata McGraw-Hill
2. Production Engineering Sciences- By Pandey and Sinh Standard Pub.
3. A text book of Production Technology- By P.C. Sharma S.Chand & Company.
4. Manufacturing Materials and Processes- By Lindberg Prentice Hall
5. A text book of Production Engineering- By P.C. Sharma S.Chand & Company.

**NOTE: In the semester examination, the examiner will set 8 questions in all, at least one question from each unit, and students will be required to attempt only 5 questions.**

\

**Lecture Plan**  
**Advanced Manufacturing Technology (ME-429N)**

<b>Month</b>	<b>Class</b>	<b>Topic/Chapter Covered</b>	<b>Academic Activity</b>	<b>Test/Assignment</b>
July	7 <sup>th</sup> Semester	Hot machining, Machining of Plastics	Teaching	
July	7 <sup>th</sup> Semester	Unit heads, Plastics cooling	Teaching	
July	7 <sup>th</sup> Semester	electro forming, Surface Cleaning and Surface Treatments,	Teaching	
July	7 <sup>th</sup> Semester	Surface Coatings, Paint Coating and Slushing	Teaching	
Aug	7 <sup>th</sup> Semester	Adhesive Bonds, Adhesive Bond Joints	Teaching	
Aug	7 <sup>th</sup> Semester	Adhesives, Surface Coating for Tooling, Graphite Mould Coating	Teaching	
Aug	7 <sup>th</sup> Semester	Vacuum Mould Process: Introduction	Teaching	
Aug	7 <sup>th</sup> Semester	Agglomerated Materials Types of Composites materials	Teaching	
Aug	7 <sup>th</sup> Semester	Reinforced materials, Laminates	Teaching	Assignment
Aug	7 <sup>th</sup> Semester	Surface Coated Materials, Production of Composite Structures,	Teaching	
Aug	7 <sup>th</sup> Semester	Fabrication of particulate composite Structures	Teaching	
Aug	7 <sup>th</sup> Semester	Fabrication of reinforced Composite	Teaching	

Aug	7 <sup>th</sup> Semester	Fabrication of Laminates, Machining	Teaching	
Aug	7 <sup>th</sup> Semester	Cutting and Joining of Composites	Teaching	
Sep	7 <sup>th</sup> Semester	Polymers: Introduction, Polymerization	Teaching	
Sep	7 <sup>th</sup> Semester	Addition of Polymers, Plastics, Types of plastics	Teaching	Assignment
Sep	7 <sup>th</sup> Semester	Properties of Plastics, Processing of Thermoplastic Plastics	Teaching	
Sep	7 <sup>th</sup> Semester	Injection Moulding, Casting of Plastics	Teaching	
Sep	7 <sup>th</sup> Semester	Machining of plastics, other processing methods of plastics Introduction	Teaching	
Sep	7 <sup>th</sup> Semester	Pin Configuration, Instruction set	Teaching	
Sep	7 <sup>th</sup> Semester	casting, thread chasing	Teaching	
Sep	7 <sup>th</sup> Semester	Thread Rolling, Die Threading and Tapping	Teaching	
Sep	7 <sup>th</sup> Semester	Thread Milling, Thread Measurement and Inspection.	Teaching	
Sep	7 <sup>th</sup> Semester	Metal Forming: Theoretical basis of metal forming	Teaching	
Oct	7 <sup>th</sup> Semester	classification of metal forming processes	Teaching	Assignment
Oct	7 <sup>th</sup> Semester	cold forming, hot working, Warm working		
Oct	7 <sup>th</sup>	Effect of variables on metal forming	Teaching	

	Semester	processes		
Oct	7 <sup>th</sup> Semester	Methods of analysis of manufacturing processes, Open Die forging	Teaching	
Oct	7 <sup>th</sup> Semester	Die Casting: Introduction, Product Application, Limitation of Die Casting	Teaching	
Oct	7 <sup>th</sup> Semester	Cold chamber machines, Die casting Design, Design of Die casting Dies, Types of Die casting Dies	Teaching	
Oct	7 <sup>th</sup> Semester	Elements of costing, cost structures, Estimation of cost elements, Methods of estimating	Teaching	
Oct	7 <sup>th</sup> Semester	Data requirements of cost estimating, Steps in making cost estimate	Teaching	
Oct	7 <sup>th</sup> Semester	Numerical examples, calculation of machining times, Estimation of total unit time	Teaching	Assignment

### **Tutorial Sheet**

#### **Unit 1 – Hot Machining and Mould Process**

1. What is hot machining?
2. Explain Machining of Plastics, Unit heads.
3. Discuss Plastics cooling and electro forming.
4. Explain Surface Cleaning and Surface Treatments, Surface Coatings.
5. What are the types of Adhesives? Explain Adhesive Bonds and Adhesive Bond Joints
6. Write a short note on Mould Process.
7. Discuss Types of Composites materials.
8. Define Reinforced materials and Laminates.
9. Write short note on
  - Fabrication of reinforced Composite

- Fabrication of Laminates

10. Explain Cutting and Joining of Composites

## **Unit 2 – Polymers**

1. What is Polymers? Explain Polymerization.
2. Explain briefly Addition of Polymers.
3. What are the Types of plastics?
4. Write a short note on Properties of Plastics.
5. Explain Injection Moulding and Casting of Plastics.
6. Explain Machining of plastics.
7. What is thread chasing?
8. What is thread Rolling?
9. Explain Die Threading and Tapping
10. What is Thread Milling? Write a short note on Thread Measurement and Inspection.

## **Unit 3 – Metal Forming**

1. What is metal forming? Write Theoretical basis of metal forming.
2. Classify metal forming processes.
3. What is cold forming, hot working?
4. Explain difference between hot working and Warm working.
5. What are the effect of variables on metal forming processes?
6. Write a short note on Methods of analysis of manufacturing processes.
7. Explain briefly Open Die forging.
8. What is Rolling Power Rolling? Explain briefly.
9. Explain Drawing operation.
10. Write short note on Extrusion.

## Unit 4 – Die Casting

1. What is die casting? Explain its product application.
2. What are the limitation of die casting?
3. Explain molten metal Injection systems.
4. Discuss hot chamber machines, Cold chamber machines.
5. Explain Die Lubrication and Coating.
6. Write Design aspects of Die casting
7. Explain briefly Elements of costing, cost structures?
8. Explain briefly the following:
  - Estimation of cost elements
  - Methods of estimating
  - Data requirements of cost estimating.
9. Discuss some chief factors in cost estimating.
10. Explain calculation of machining times and Estimation of total unit time.

**B TECH (7<sup>th</sup> Semester)**  
**ADVANCED MANUFACTURING TECHNOLOGY**  
**ME-429N/D18**

*Time allowed: 3 hours*

*Maximum marks: 75*

**UNIT-1**

- 9) Write Short notes on following processes:
- |                      |   |
|----------------------|---|
| (a) Surface coatings | 5 |
| (b) Electroforming   | 5 |
| (c) Adhesive Bonds   | 5 |
- 10) Describe with neat sketches various fabrication techniques used in making reinforced composites. 15

**UNIT-2**

- 11) Explain with neat sketches, the application of Injection moulding and compression moulding processes for processing plastics. 15
- 12) Discuss with neat sketches, various thread measurement and inspection techniques. Describe advantages and limitations of each of these. 15

**UNIT-3**

- 13) (a) What do you mean by drawing process? Discuss various methods of Tube or Pipe Drawing. 10
- (b) Discuss various applications of Hot working and Cold working processes. 5
- 14) Describe the following processes :
- |                      |   |
|----------------------|---|
| (a) Open Die Forging | 5 |
| (b) Extrusion        | 5 |
| (c) Rolling          | 5 |

#### UNIT-4

15) Describe the advantages and limitations of Die Casting. Differentiate between hot Chamber and Cold chamber die casting machine. Explain the application of each with neat sketches. 15

16) Write Short notes on following :

- (a) Various methods of cost estimation 8
- (b) Elements of costing and cost structure. 7

**B. Tech. 7<sup>th</sup> Semester Mechanical Engineering**

Course No.	Course Title	Teaching Schedule			Allotment of Marks			Duration of Exam (Hrs.)
		L	T	P	Sessional	Practical	Total	
ME-405N	MEASUREMENT AND CONTROL LAB	0	0	2	40	60	100	3
CO1	Knowledge of the LVDT system and its applications.							
CO2	Knowledge of torque and pressure pick-ups and its applications and measuring ability.							
CO3	Knowledge of thermocouple and its applications.							
CO4	Knowledge of non-contact type measuring devices such as LDR (light dependent resistor) and speed pick-ups.							
CO5	Knowledge and ability to use load cell and perform measurement.							
CO6	Knowledge of strain gauges and ability to perform measurements.							

**LIST OF EXPERIMENTS:**

1. Study of a strain gage based cantilever beam and measurement of strain on the beam
2. Study of a LVDT and measurement of linear displacement
3. Study of an inductive pick up and measurement of linear displacement
4. Study of a LDR and measurement of linear displacement
5. Study of capacitive pick up and measurement of angular displacement
6. Study of temperature transducers and measurement of temperature of fluid
7. Study of a LVDT (strain gage based) and measurement of linear displacement.
8. Study of a torque pick up and measurement of torque .
9. Study of a pressure pick up and measurement of pressure of fluid.
10. Study of load cell and measurement of load with load cell
11. Study of non-contact type speed pick up and measurement of rotational speed
12. Comparison of sensitivity of thermocouple, thermister and RTD

Note: **At least eight experiments should be performed from the above list.**

<b>B. Tech. 7<sup>th</sup> Semester Mechanical Engineering</b>									
<b>Course No.</b>	<b>Course Title</b>	<b>Teaching Schedule</b>			<b>Allotment of Marks</b>			<b>Duration of Exam (Hrs.)</b>	
		<b>L</b>	<b>T</b>	<b>P</b>	<b>Sessional</b>	<b>Practical</b>	<b>Total</b>		
<b>ME-407N</b>	<b>MECHATRONICS LAB</b>	0	0	2	40	70	100	3	
<b>CO 1</b>	Able to perform operations on Assembly language programming of 8085								
<b>CO 2</b>	Able to understand distinguish hydraulic and pneumatic control system								
<b>CO 3</b>	Able To demonstrate experiments on DC motor, traffic light and stepper motor interface								
<b>CO 4</b>	Able to demonstrate working of sensors and transducer.								

#### **LIST OF EXPERIMENTS:**

1. To perform various operation on Assembly language programming of 8085 – Addition – Subtraction Multiplication – Division – Sorting – Code Conversion.
2. To Study Stepper motor interface.
3. To study the Traffic light interface using a PLC kit.
4. To Perform Speed control of DC motor kit.
5. To Study various types of Sensors and transducers.
6. To Study hydraulic System.
7. To study Pneumatic and electro-pneumatic circuits.
8. To study PLC and its applications.
9. To Study image processing technique.

**Note: Any 8 experiments from the above list and other 2 from others (developed by institute) are required to be performed by students in the laboratory.**

**B. Tech. 7<sup>th</sup> Semester Mechanical Engineering**

Course No.	Course Title	Teaching Schedule			Allotment of Marks			Duration of Exam
		L	T	P	Sessional	Practical	Total	
<b>ME-409N</b>	<b>PROJECT-1</b>	0	0	8	100	100	200	3
<b>Purpose</b>	To know the method of programming the microprocessor and also the design, modeling & analysis of basic electrical, hydraulic & pneumatic Systems which enable the students to understand the concept of mechatronics.							
<b>Course Outcomes</b>								
<b>CO 1</b>	Able to perform operations on Assembly language programming of 8085							
<b>CO 2</b>	Able to understand distinguish hydraulic and pneumatic control system							
<b>CO 3</b>	Able To demonstrate experiments on DC motor, traffic light and stepper motor interface							
<b>CO 4</b>	Able to demonstrate working of sensors and transducer.							

The students expected to take up a project under the guidance of teacher from the college. The project must be based on mechanical engineering problems, which can be extended up to the full semester. The students may be asked to work individually or in a group not more than four students in a group. Viva- voce must be based on the preliminary report submitted by students related to the project.

**B. Tech. 7<sup>th</sup> Semester Mechanical Engineering**

<b>ME-411N</b>	<b>INDUSTRIAL TRAINING ( VIVA-VOCE)</b>					
<b>Lecture</b>	<b>Tutorial</b>	<b>Practical</b>	<b>Sessional</b>	<b>Practical</b>	<b>Total</b>	<b>Duration of Exam. (Hrs.)</b>
<b>2</b>	<b>0</b>	<b>0</b>	<b>40</b>	<b>60</b>	<b>100</b>	<b>3</b>

The training report will be submitted by the students along with the certificate indicating the duration of training and the nature of Project-done.

The students will have to appear for viva-voce examination based on training performed at the end of previous semester in industries.

<u>B. Tech. 7<sup>th</sup> Semester Mechanical Engineering</u>						
ME-413N	SEMINAR- I					
Lecture	Tutorial	Practical	Sessional	Practical	Total	Duration of Exam. (Hrs.)
0	2	0	100	0	100	

The students are required to deliver a seminar on some emerging areas of Mechanical Engineering, given as follows:

- CAD/CAM/CAE/FEA
- Robotics
- Machine Vision
- Automation
- Tribology
- CFD
- Energy Conservation
- Alternate Energy Sources
- Hybrid Fuels
- Advances in IC Engines
- Vehicle Dynamics
- Aerodynamics
- Advanced Manufacturing Techniques
- Advanced Engineering Materials
- Supply Chain Management
- Business Process Re-engineering
- Six-Sigma Technique
- Lean Manufacturing Technique
- Just-in-Time Technique
- Agile Manufacturing
- Value Engineering
- Reliability Engineering
- Any other topic related to Design/Thermal/Industrial/Production Engineering

The student will deliver a power point presentation for about 30 minutes in the seminar on any of the above topics. This will be followed by question answering session for about 10 minutes. The questions on the seminar topic will be asked by the teacher concerned and class students. The students will also prepare a detailed report in MS word and after spiral binding will submit it to the teacher concerned. The report is to be submitted at least one week prior to the presentation. The grades/awards will be given according to the student's presentation, report submitted, and answering of questions asked after the presentation.