

ES-101A BASIC ELECTRICAL ENGINEERING							
L	T	P	Credit	Major Test	Minor Test	Total	Time(Hrs)
4	1	-	5	75	25	100	3
<b>Purpose</b>	<b>To familiarize the students with the basics of Electrical Engineering</b>						

#### Course Outcomes:-

CO1	To understand the basic concepts of dc circuits and network theorems.
CO2	To gain knowledge of basics of ac circuits.
CO3	To understand the three phase system and magnetic circuits.
CO4	To explain the construction and working of single phase transformer, auto transformer.
CO5	To understand the working, types and applications of dc machine and induction machine. To explain the construction and Working principle of synchronous generator and motor.
CO6	To understand about electrical installation that is switch fuse unit(sfu), mcb, elcb ,mccb , types of wires and cables, earthing

#### Unit-I

**D.C. circuits:** Ohm's Law, junction, node, circuit elements classification: Linear & nonlinear, active & passive, lumped & distributed, unilateral & bilateral with examples. KVL, KCL, Loop and node-voltage analysis of resistive circuit. Star-Delta transformation for resistors.

**Network Theorems:** Superposition, Thevenin's, Norton's and Maximum power transfer theorems in a resistive network.

#### Unit-II

**AC Fundamentals:** Mathematical representation of various wave functions. Sinusoidal periodic signal, instantaneous and peak values, polar & rectangular form of representation of impedances and phasor quantities. Addition & subtraction of two or more phasor sinusoidal quantities using component resolution method. RMS and average values of various waveforms.

**A.C. Circuits:** Behavior of various components fed by A.C. source (steady state response of pure R, pure L, pure C, RL, RC, RLC series with waveforms of instantaneous voltage, current & power on simultaneous time axis scale and corresponding phasor diagrams), power factor, active, reactive & apparent power. Frequency response of Series & Parallel RLC ckts. including resonance, Q factor, cut-off frequency & bandwidth. Generation of alternating emf.

#### Unit-III

**Balanced Three Phase Systems:** Generation of alternating 3- phase emf). 3-phase balanced circuits, voltage and current relations in star and delta connections. Measurement of 3-phase power by two wattmeter method for various types of star & delta connected balanced loads.

**Single Phase Transformer** (qualitative analysis only): Concept of magnetic circuits. Relation between MMF & Reluctance. Hysteresis & Eddy current phenomenon. Principle, construction & emf equation Phasor diagram at ideal, no load and on load conditions. Losses & Efficiency, regulation. OC & SC test, equivalent circuit, concept of auto transformer.

#### Unit-IV

**Electrical Machines** (qualitative analysis only): Construction and working of dc machine with commutator action, speed control of dc shunt motor. Generation of rotating magnetic fields, Construction and working of a three-phase induction motor, Significance of torque-slip characteristic. Basics of Single-phase induction motor, capacitor start capacitor run Single-phase induction motor working. Basic construction and working of synchronous generator and motor.

**Electrical Installations (LT Switchgear):** Switch Fuse Unit (SFU), MCB, ELCB, MCCB, Types of Wires and Cables, Earthing.

#### Suggested Books:

1. Basic Electrical Engg: A complete Solution by Vijay Kumar Garg, Wiley India Ltd.
2. Electrical Engg. Fundamentals by Rajendra Prasad, PHI Pub.
3. Basic Electrical Engg. by S.K. Sahdev, Pearson Education

4. Electrical Engg. Fundamentals: by Bobrow, Oxford Univ. Press
5. Basic Electrical Engg. By Del Toro.
6. Saxena & Dasgupta: Fundamentals of Electrical Engg (Cambridge University Press).

**Note: The paper setter will set the paper as per the question paper templates provided.**

ES-103LA		BASIC ELECTRICAL ENGINEERING LAB					
L	T	Practical	Credit	Minor Test	(Practical)	Total	Time (Hrs)
-	-	2	1	20	30	50	3
Purpose		To familiarize the students with the Electrical Technology Practicals					
Course Outcomes							

C01	Ability to understand the basic laws and network theorem.
C02	To understand the resonance of ac series and parallel circuits.
C03	Ability to conduct the various tests of single phase transformer.
C04	Ability to conduct testing and experimental procedures of various dc machines.
C05	To understand domestic wiring scheme procedure.
C06	To understand the working and troubleshooting of tube light.

### LIST OF EXPERIMENTS

1. To verify KVL and KCL.
2. To verify Superposition theorem on a linear circuit with at least one voltage & one current source.
3. To verify Thevenin's Theorem on a linear circuit with at least one voltage & one current source.
4. To verify Norton's Theorem on a linear circuit with at least one voltage & one current source.
5. To study frequency response of a series R-L-C circuit on CRO and determine resonant frequency & Q-factor for various Values of R, L, and C.
6. To study frequency response of a parallel R-L-C circuit on CRO and determine resonant frequency & Q-Factor for various values of R, L, and C.
7. To perform O.C. and S.C. tests on a single phase transformer.
8. To perform direct load test on a single phase transformer and plot efficiency v/s load characteristic.
9. To perform speed control of DC shunt motor.
10. To perform starting & reversal of direction of a three phase induction motor.
11. Measurement of power in a 3 phase balanced system by two watt meter method.
12. Study of Cut sections of DC Machines, Induction Motor
13. To study components of various LT Switchgears

**Note: At least 9 out of the listed experiments to be performed during the semester.**

# BASIC ELECTRICAL ENGINEERING (ES-101A)

## LESSON PLAN

LECTURE	CONTENT
L-1	<b>Dc Circuits:-</b> Ohm's Law, junction & node, circuit elements classification
L-2	Linear & nonlinear, active & passive, lumped distributed, unilateral & bilateral with examples
L-3	KVL, KCL, Loop analysis of resistive circuit in the context of dc voltages & currents
L-4	Node-voltage circuit in the context of dc voltages & currents
L-5	Star-Delta analysis of resistive transformation for set of pure resistors
L-6	<b>Network Theorems:</b> Superposition
L-7	Thevenin's and Norton's theorems
L-8	maximum power transfer theorem
L-9	Relevant D.C. circuit analytical problems for quantitative analysis.
L-10	<b>AC Fundamentals:</b> Mathematical representation of various wave functions, Sinusoidal periodic signal, instantaneous & peak values
L-11	polar & rectangular form representation of impedances & phasor quantities
L-12	Addition & subtraction of two or more phasor sinusoidal quantities using component resolution method
L-13	RMS & average values of various waveforms
L-14	<b>A.C. Circuits:</b> Behavior of various components fed by A.C. source. steady state response of pure R, pure L
L-15	Behavior of pure C, RL series circuit
L-16	RC, RLC series with waveforms of instantaneous voltage, current & power on simultaneous real axis scale and corresponding phasor diagrams)
L-17	P.F.active, reactive & apparent power
L-18	Frequency response of Series & Parallel RLC circuit including resonance, Q factor, cut-off frequency & bandwidth
L-19	<b>Balanced Three Phase Systems:</b> generation of 3 phase supply, 3-phase balanced circuits,
L-20	voltage and current relations in star and delta connections.
L-21	Measurement of 3-phase power by two wattmeter method for various types of star & delta connected balanced loads.
L-22	<b>Single Phase Transformer (Qualitative analysis only):</b> ) Concept of magnetic circuits. Relation between MMF & Reluctance. Hysteresis & Eddy current phenomenon.
L-23	Principle, construction of transformer
L-24	emf equation Phasor diagram of ideal transformer
L-25	no load and on load conditions
L-26	Losses & Efficiency of transformer
L-27	regulation. OC & SC test
L-28	equivalent circuit of transformer
L-29	concept of auto transformer.
L-30	<b>Electrical Machines (qualitative analysis only):</b> Construction of Dc Machine.
L-31	working of dc machine with commutator action
L-32	speed control of dc shunt motor
L-33	Generation of rotating magnetic fields
L-34	Construction and working of a three-phase induction motor
L-35	Significance of torque-slip characteristic.
L-36	Basics of Single-phase induction motor
L-37	capacitor start capacitor run Single-phase induction motor working
L-38	Basic construction & working of synchronous generator and motor.
L-39	<b>Electrical Installations (LT Switchgear):</b> Switch Fuse Unit (SFU), MCB

L-40	ELCB, MCCB, Types of Wires and Cables
L-41	Earthing.

## Basic Electrical Engineering (ES-101A) Tutorial Sheets

### Unit- I

- Convert delta connected set of 3 resistors R into star.
- Explain maximum power transfer theorem with proper mathematical treatment & its significance.
- Two equal resistors R connected in series across a voltage source V dissipated power P. What would be the power dissipated in the same resistors when they are connected in parallel across the same voltage source?
- Convert star connected set of 3 resistors R into delta.
- Differentiate between the following circuit elements by giving examples also: (i) Linear & Non-linear, (ii) Lumped & Distributed, (iii) Active & Passive, (iv) Unilateral & Bilateral, (v) Junction & Node.
- State & explain Kirchoff's Law. What are the limitations & applications of Kirchoff's law in circuit theory?
- How Norton's Theorem is equivalent to Thevenin's Theorem? Also write the limitations of Thevenin's Theorem & find the voltage across load resistance  $R_L$  using Thevenin's Theorem when load resistance is 2 kilo-ohm.

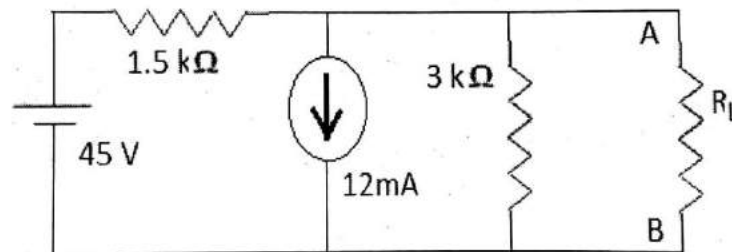

- What do you mean by Apparent power, Active power & Reactive power?
- Define Bilateral & Unilateral elements with example.
- Determine effective resistance between the terminals A-B in the network shown below:

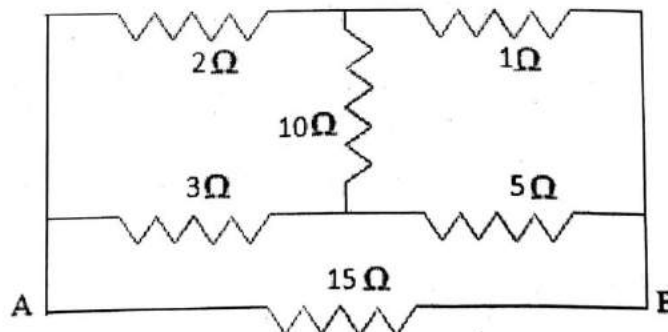

- Find current in 2 ohm resistance in the following circuit using Loop Analysis Method:

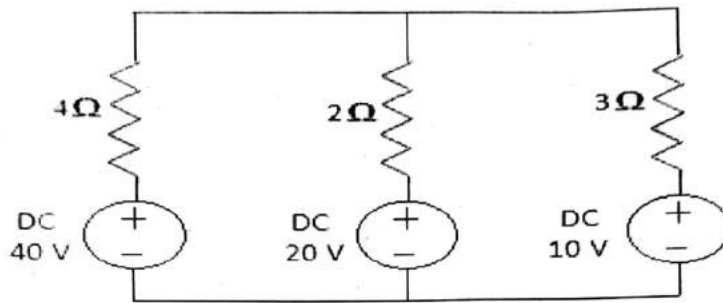

- Solve the network & find the current in each branch.

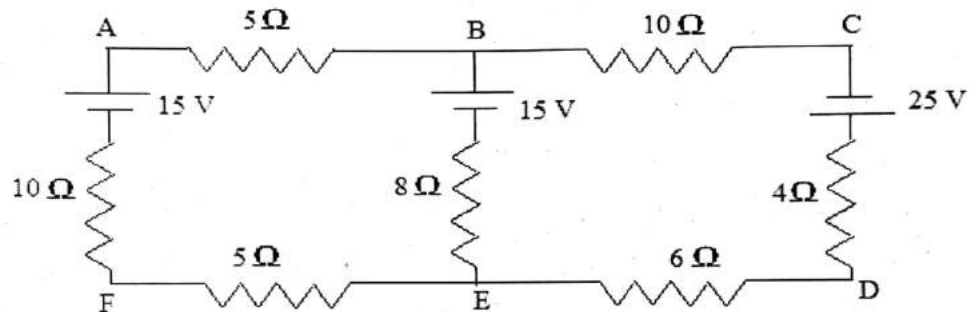

- For the circuit shown, derive the Thevenin's & Norton's equivalents w.r.t. the connected load resistance R.

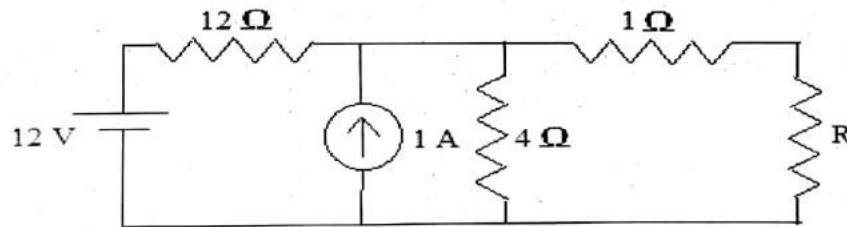

- For the circuit shown at right, all resistors are of 1 kΩ. Find the equivalent resistance between terminals (i) A & B, (ii) C & D, (iii) B & C.

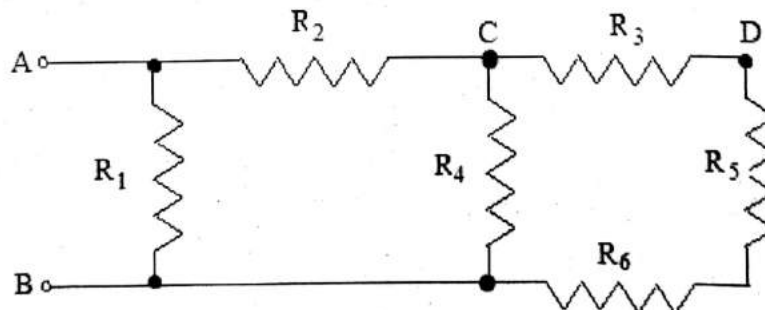

- For the circuit shown, find the voltage between B & C using superposition.

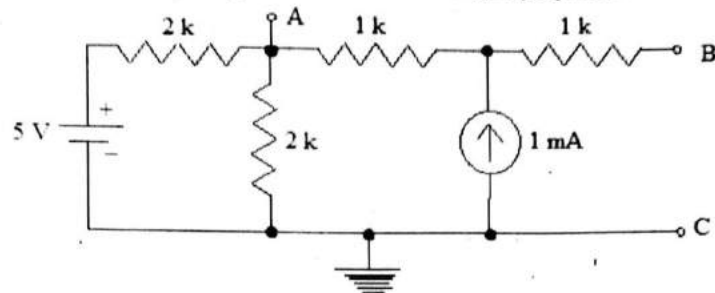

- Three resistors 12 ohm, 18 ohm & 36 ohm are connected in parallel. The parallel circuit is connected in series with a resistor R. The whole circuit is connected to supply of 60 volt & it is found that power developed in 12 ohm resistor is 48 watts. Determine the value of R & total power.
- In the circuit shown, the value of load resistance R is chosen so that the load power dissipation is maximized:
  - Derive the Thevenin's equivalent of the network to which the load resistance R is connected.
  - Calculate the value of R to maximize the load power dissipation & the value of the maximum load power.

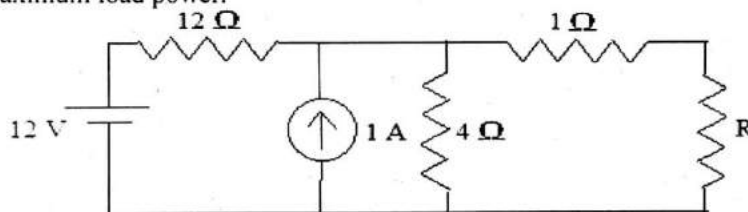



## Unit- II

- An ac wave ( $V = V_m \sin \theta$ , where  $\theta = \omega t$ ), is made half wave rectified. Find out its r.m.s. value for complete cycle.
- Find out the active power delivered in watt, to an impedance  $Z = (4 - j3) \Omega$  by a current  $i = 5 \cos (100 \pi t + 100) \text{ A}$ .
- Given in volts:  $V_1 = 50 \cos \omega t$ ,  $V_2 = 50 \sin (\omega t - 135^\circ)$ , Find  $V = V_1 + V_2$  in sinusoidal form.
- Explain in detail the theory of sinusoidal frequency response of series RLC ckt. Including series resonance, with neat diagrams & various waveforms.
- A series RLC circuit with  $R = 10 \Omega$ ,  $L = 100 \text{ mH}$  &  $C = 2 \mu\text{F}$  is connected to an AC voltage source which has a maximum amplitude  $V_m = 100 \text{ V}$ , (i) what is the resonant frequency  $\omega_0$ ? (ii) find the rms current at resonance. (iii) Let the driving frequency be  $\omega = 1000 \text{ rad/s}$ , then compute  $X_C$ ,  $X_L$ , and  $Z$ .
- A series RLC circuit with  $R = 10 \Omega$ ,  $L = 400 \text{ mH}$  &  $C = 2 \mu\text{F}$  is connected to an AC voltage source which has a maximum amplitude  $V_m = 100 \text{ V}$ , (i) what is the resonant frequency  $\omega_0$ ? (ii) find the rms current at resonance. (iii) Let the driving frequency be  $\omega = 4000 \text{ rad/s}$ , then compute  $X_C$ ,  $X_L$ , and  $Z$ .
- Find average and r.m.s., values of the voltage waveform shown in fig.

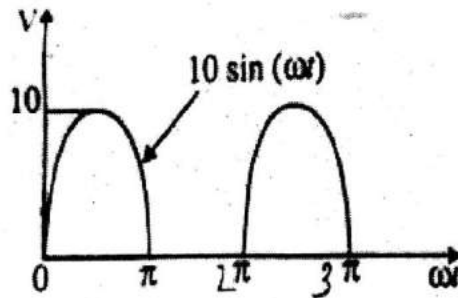

- Derive the expression of resonance frequency of parallel RLC circuit in series-parallel circuit A & B are in series with C. The impedance are  $Z_A = 4 + j3 \Omega$ ,  $Z_B = 4 - j5 \Omega$  and  $Z_C = 2 + j8 \Omega$ . If the current  $I_C = 25 + j0$ , calculate: (i) branch voltage; (ii) branch currents; (iii) total power; and (iv) phasor diagram.

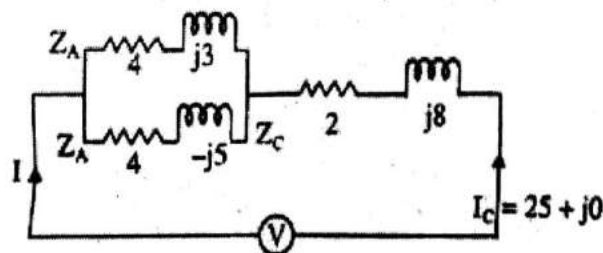

### Unit- III

- Explain in detail the two wattmeter method of power measurement for star connected resistive load with suitable steps containing equations, ckt. & phasor diagram.
- Explain open & short circuit test in a single phase transformer with the help of neat sketches.
- Explain an ideal transformer with the help of phasor diagram.
- Explain & draw in detail the phasor diagram of an actual transformer having capacitive load (RC series) with suitable steps containing equations & circuit diagram.
- Explain with application also the following: (i) RH Screw Rule, (ii) Fleming's RH Rule, (iii) Fleming's LH Rule.
- Explain single phase auto transformer, & give its two applications.
- In the two wattmeter method of power measurement in a 3-phase circuit, the readings of the wattmeter are 2000 W and 500 W. What is the total power & power factor of the load?
- Derive relation between line & phase values in delta connected 3-phase balance system. A three phase voltage source has a phase voltage of 120 V and supplies star connected load having impedance of  $24 + j36$  ohm per phase. Calculate (i) line voltage; (ii) line current; and (iii) total three-phase power supplied to the load.
- Explain why the hysteresis loss & eddy current loss occur in transformer. Explain how these losses can be reduced in a transformer.
- Define the following with respect to a magnetic circuit:  
(i) Magneto motive force; (ii) Flux; (iii) Reluctance; (iv) Flux density; and (v) Magnetic field intensity

## Unit- IV

- Explain in detail the construction & working of a DC motor with suitable sketches.
- Draw neatly the following waveforms on simultaneous  $\omega t$  scale:  $V_1 = V_m \sin \omega t$ ,  $V_2 = V_m \sin (\omega t - 120^\circ)$ , &  $V_3 = V_m \sin (\omega t - 240^\circ)$ . Hence, explain how is a 3-phase pulsating magnetic flux in the stator of a 3-phase induction motor equivalent to a single bipolar rotating field moving with synchronous speed with suitable steps containing neat sketches. On the basis of the phenomenon, explain in brief, the cause of rotation in a 3-phase squirrel cage induction motor.
- Explain the construction of a DC generator with neat sketches.
- Explain the principle, general construction & working of synchronous motor with suitable sketches.
- Explain in detail the construction of a slip ring type 3-phase induction motor with neat sketches.
- Derive the expression for generated emf in DC machine. Explain the term back emf when applied to DC motor. Briefly explain what role back emf play in the starting & running of the motor.
- Draw the slip vs torque characteristics of the 3-phase induction motor & indicate (i) stable operating region and (ii) induction generator operating region.
- Discuss the use of damper winding for starting a synchronous motor
- Why is the synchronous motor not self starting? Explain the advantages & disadvantages along-with applications of synchronous motor.
  
- write a short note on:-
  - (i) MCB
  - (ii) ELCB
  - (iii) MCCB
- Describe the various types of wires and Cables.
- What is the importance of Earthing?

Roll No. ....1218712

Total Pages : 4

BT-1/D-18

31044

BASIC ELECTRICAL ENGINEERING

Paper : ES-101(A)

Opt. (I)

Time : Three Hours]

[Maximum Marks : 75

Note : Attempt five questions selecting at least one question from each unit.

UNIT-I

1. (a) Using Mesh analysis, determine the current in the  $4\ \Omega$ -branch in the circuit shown in Fig. 1. 8

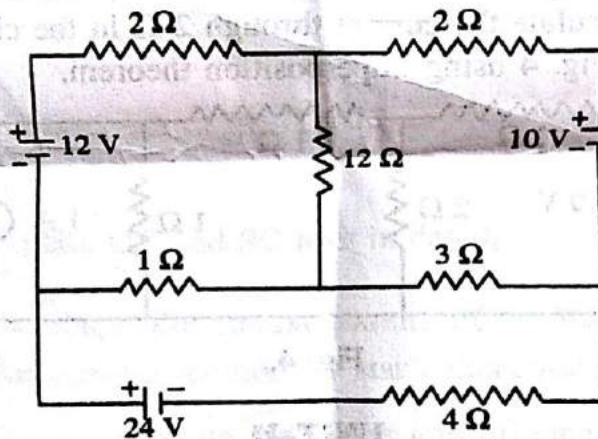
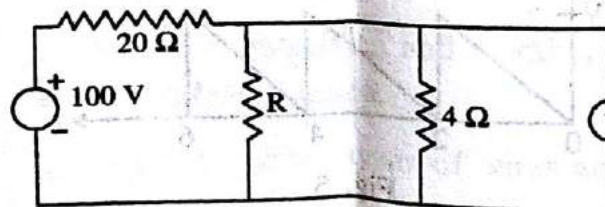

Fig. 1.

- (b) For the circuit shown in Fig. 2, find out the value of  $R$  for maximum power transfer, and also find out the maximum value of power. 7



$V = IR$   
 $V = 16V$

31044/1,100/KD/1673

Fig. 2.

[P.T.O.]  
22/12

2. (a) Using Node voltage method, find  $V_s$  for  $I_o = 7.5$  mA as shown in Fig. 3. 8

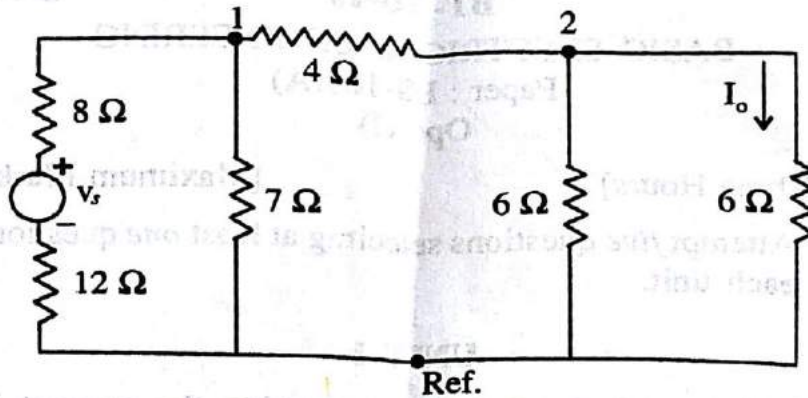

Fig. 3.

- (b) Calculate the current through  $2 \Omega$  in the circuit shown in Fig. 4 using Superposition theorem. 7

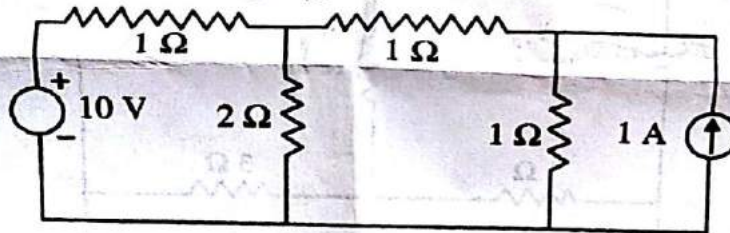

Fig. 4.

### UNIT-II

3. (a) Calculate the r.m.s. and average value for the waveform shown in Fig. 5. (4+4)

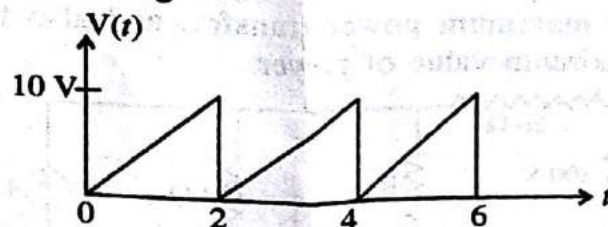

Fig. 5.

31044/1,100/KD/1673

2



(b) Find selectivity, Q factor, half power frequencies and bandwidth for Parallel RLC resonance circuit. 7

4. (a) Find the sum of sine current given as follows : 8

$$i_1 = 12 \sin (\omega t + 30^\circ); i_2 = 20 \sin (\omega t + 60^\circ),$$

$$i_3 = 18 \sin \omega t; i_4 = 25 \cos (\omega t); i_5 = 10 \cos \left( \omega t + \frac{2\pi}{3} \right).$$

(b) Draw and explain resonance and bandwidth curve for series RLC resonance circuit. 7

### UNIT-III

5. (a) Describe Three-phase delta connection with diagrams. 8

(b) Explain OC and SC tests in detail. 7

6. (a) Describe the measurement of 3-phase power by 2-wattmeter method for star connection. 8

(b) Write a note on the losses and efficiency of a single phase transformer. 7

### UNIT-IV

7. (a) Explain the construction and working of dc machines with commutator action. 8

(b) Describe the various types of wires and cables. 7

31044/1,100/KD/1673

3

[P.T.O.]

8. (a) Explain the construction and working principle of synchronous generator and motor. 8

(b) Differentiate between MCB, ELCB and MCCB. 7

$$\left( \frac{\pi R}{3} + \omega t \right) \cos 10 \cos 10 = 23 \cos 10 \cos 10 = 18 \sin 10 \cos 10 = 12 \sin 10 \cos 10 = 10 \sin 10 \cos 10$$

(b) Draw and explain resonance and bandwidth curve for series RLC resonance circuit. 7

UNIT-III

1. Explain the construction and working principle of synchronous generator and motor. 8

(b) Explain OC and SC test in detail. 7

(a) Describe the measurement of 3-phase power by 3-wattmeter method for star connection. 8

(b) Write a note on the losses and efficiency of a single phase transformer. 7

UNIT-IV

(a) Explain the construction and working of dc machines with commutator action. 8

(b) Describe the various types of wires and cables. 7